

IBC 2009/2012  
COMPLIANT

**UMP** UNITED METAL PRODUCTS  
WWW.UNITEDMETALPRODUCTS.INFO



# Supreme Framing System

## *Product Catalog*



SUPREME FRAMING SYSTEM™

## The Benefits of Supreme Framing System™ Speak for Themselves

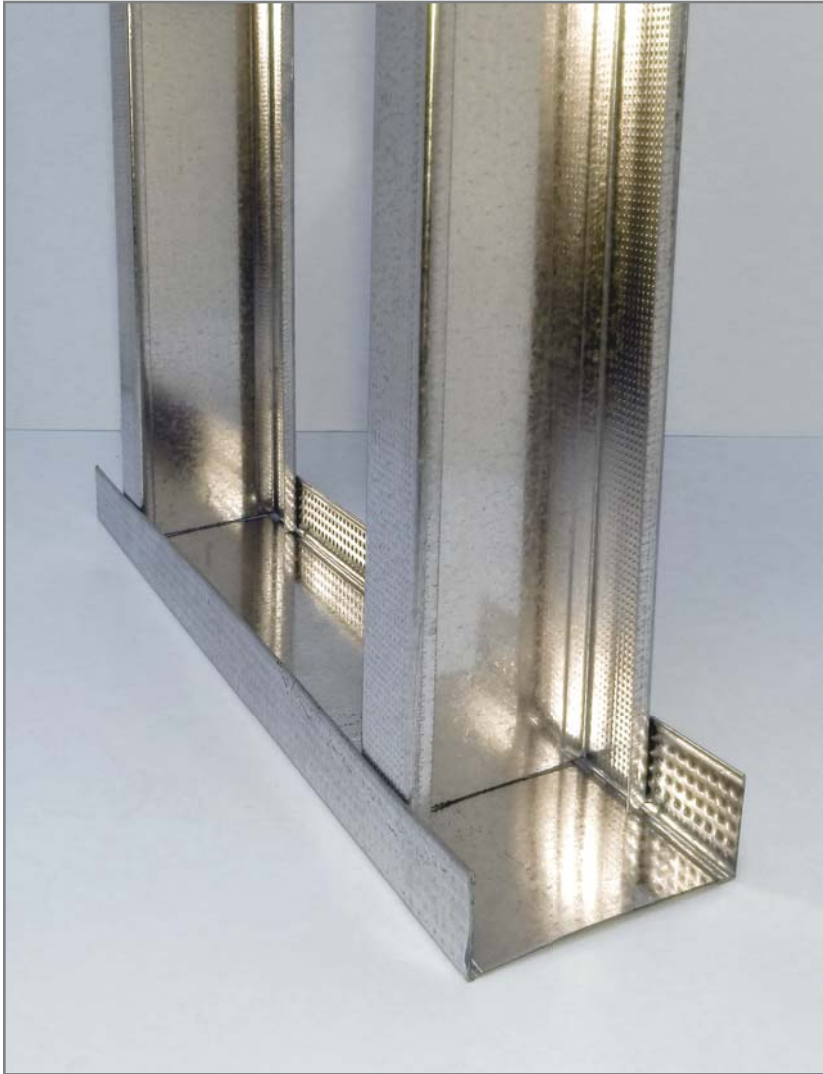

### *What is the Supreme Framing System™?*

Supreme Framing System™ stud and track is a design that uses thinner steel and superior 57 ksi yield strength when compared to traditional material. Supreme Framing System™ is available nationally through multiple independent steel stud manufacturers.

- Complies with 2009 and 2012 IBC
- Multiple UL approved fire-rated assemblies
- Excellent acoustical performance
- 57 ksi steel reduces screw stripping
- Fastens with sharp point screws (30EQD, 33EQD, D20, and D25)
- Wider flanges for screw placement
- Full line of Supreme Framing accessories
  - Hat Channel and Z-Furring
  - Slotted Track
  - Custom Brake Shapes

### *Supreme is Certified!*

All inspections and testing for the Supreme Steel Framing System Association (SSFSA) are provided by Architectural Testing, Inc. SSFSA sponsors a third-party certification program that requires products to be continually audited to ensure consistent quality and compliance to ASTM C645, C955, and IBC Codes.

Stud and track products must be tested on unannounced visits. Steel is chemically stripped and tested for coating weight and bare metal thickness. The dimensional properties of the stud are also measured. All requirements must be satisfied in order to be certified code compliant. All members of the SSFSA must satisfy the requirements each time they are audited.

All certified Supreme Steel products has a label showing that it is third-party certified. Labels may be located on bundles or each framing member. The third-party certification label guarantees to the contractor and owner that materials are high quality and code compliant.



### **Look for the sticker!**

Third-party certified code compliant by nationally recognized Architectural Testing, Inc.

**Table of Contents**

**Technical Information.....4-7**  
 Nomenclature Example.....4  
 Supreme Stud Profiles.....4  
 General Notes for All Tables.....5  
 Steel Thickness and Stiffening Lip Length.....5  
 Screw and Weld Capacities.....6  
 Web Depth-to-Thickness Ratios.....7

**Section Property Symbols.....7**  
 Definitions of Symbols.....7

**Section Properties.....8-11**  
 Nonstructural Studs (SFS).....8  
 Structural Studs (SFS).....9  
 Track (SFT).....10-11

**Composite Interior Wall Heights.....12**

**Non-Composite Interior Wall Heights.....13-17**

**Curtain Wall Limiting Heights.....18-21**

**Combined Axial and Lateral Loads.....22-24**

**Ceiling Spans.....25-26**  
 Ceiling Spans.....25  
 Mid-Span Bracing Details.....26

**Hat Channel Section Properties.....26**

**Hat Channel Spans.....27**

**Web Crippling Loads.....28**  
 Web Crippling Loads.....28  
 Web Crippling Conditions.....28

**Supreme Acoustical Performance Testing.....29**

**Supreme Fire-Rated Assemblies.....30**  
 UL Approved Designs.....30

**Supreme Deep Leg Deflection Track.....31**

**Supreme Z-Furring.....31**

**Locations.....Back Cover**

**LEED Credits**

- MR Credit 2 - Construction Waste Management (1-2 points)
- MR Credit 4 - Recycled Content (1-2 points)
- MR Credit 5 - Regional Materials (1-2 points)

**Independent Product Certification**

- Code Compliance - ICC Evaluation Services, LLC
- Fire Testing - Underwriters Laboratories, Inc.
- Sound Ratings - Riverbank Acoustical Laboratories
- Third-Party Testing - Architectural Testing, Inc.
- Structural Testing - O.S.U. (Oregon State University) STAR Laboratories
- Structural Engineer - DEVCO Engineering

**Code Approvals, Performance Standards, and Product Certifications**

AISI's "North American Specification for the Design of Cold-Formed Steel Structural Members"

**American Society for Testing and Materials (ASTM)**

- A653 - Standard Specification for Steel Sheet, Zinc-Coated (Galvanized) by the Hot-Dip Process
- A1003 - Standard Specification for Steel Sheet, Carbon, and Metallic-Coated for Cold-Formed Framing Members
- C645 - Standard Specification for Non-Structural Steel Framing Members
- C754 - Standard Specification for Installation of Steel Framing Members to Receive Screw-Attached Gypsum Panel Products
- C955 - Standard Specification for Load-Bearing (Transverse and Axial) Steel Studs, Runners (Tracks), and Bracing or Bridging for Screw Application of Gypsum Panel Products and Metal Plaster Bases
- C1007 - Standard Specification for Installation of Load Bearing (Transverse and Axial) Steel Studs and Related Accessories
- E72 - Standard Test Methods of Conducting Strength Tests of Panels for Building Construction
- E90 - Standard Test Method for Laboratory Measurement of Airborne Sound Transmission Loss of Building Partitions and Elements
- E119 - Standard Test Methods for Fire Tests of Building Construction and Materials

## Nomenclature Example

All products have a four-part identification code that identifies the web depth, flange width, style, and mil thickness.

### Member Web Depth

(Example: 6" = 600 × 1/100 inch)

All member depths are given in 1/100 inch.

For all "T" sections, member depth is the inside to inside dimension.

### Flange Width

(Example: 1 5/8" = 1.625" ≈ 162 × 1/100 inch)

All flange widths are given in 1/100 inch.

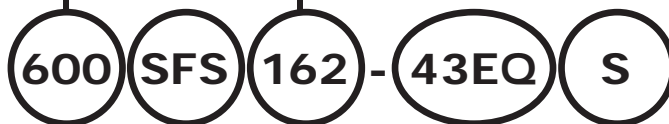

### Style

(Example:

Supreme Framing Stud section = SFS)

Nomenclature uses the following characters to designate the profile:

**SFS** = Supreme Framing Stud or Joist Sections

**SFT** = Supreme Framing Track Sections

**F** = Furring Channel Sections

### Thickness Designation

See Thickness Tables on page 5.

### Design Type

(Example: Structural section = S)

Nomenclature uses the following two characters:

**S** = Structural studs and track

**D** = Drywall (Non-Structural) studs and track

## Supreme Stud Profiles

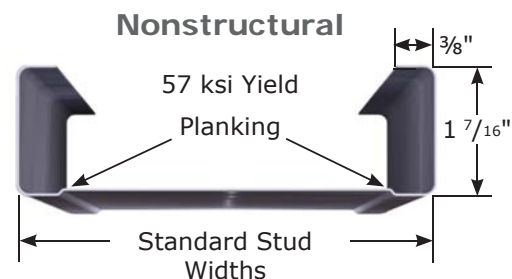

### Available Sizes

1 5/8", 2 1/2", 3 1/2", 3 5/8", 4", 5 1/2" and 6"

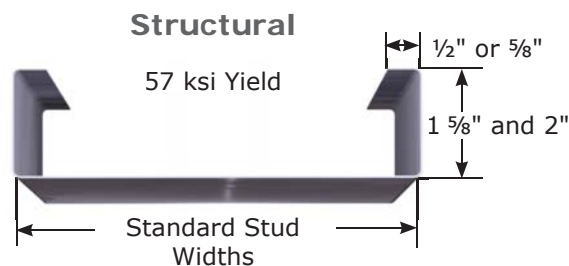

### Available Sizes

2 1/2", 3 1/2", 3 5/8", 4", 5 1/2", 6", and \*8"

\*available in 43EQS only

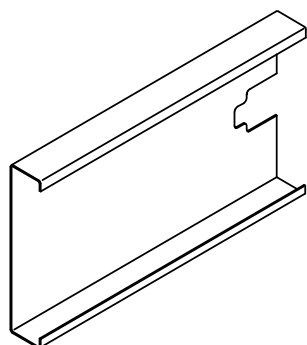

"S" - C-STUD/JOIST  
S-SECTIONS

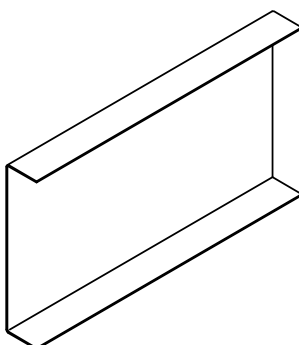

"T" - TRACK  
T-SECTIONS

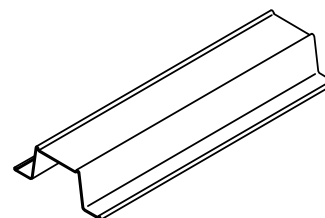

"F" - FURRING CHANNEL  
F-SECTIONS

## General Notes for All Tables

1. The values in this catalog are based on the 2007 edition of North American Specification for the Design of Cold-Formed Steel Structural Members, AISI S100-07 as referenced by 2009 International Building Code (IBC) and AISI S100-07 with Supplement S2-10 as referenced by 2012 IBC.
2. Where AISI S100 is referenced, it is the North American Specification for the Design of Cold-Formed Steel Structural Members, S100-07 and AISI S100-07 with Supplement S2-10, as applicable with U.S. provisions.
3. The structural properties included herein have been computed based on allowable strength design (ASD) method.
4. Distortional buckling calculations are based on  $K\phi = 0$ .
5. The effective moment of inertia for deflection is calculated at a stress that results in a section modulus such that the stress times the section modulus at that stress is equal to the allowable moment. AISI S100 Procedure I for serviceability determination has been used.
6. Conditions with loads that exceed the 10 psf limit for nonstructural members require a G60 galvanized coating.
7. When provided, factory punchouts will be located along the center line of the webs of the stud members and will have a minimum center-to-center spacing of 24". Punchouts for members greater than 2 1/2" deep are a maximum of 1 1/2" wide x 4 1/2" long. Members with depths 2 1/2" and smaller are maximum 3/4" wide x 4 1/2" long. Any configuration or combination of holes that fit within the punchout width and length limitations mentioned above shall be permitted; other punchout configurations and locations not in compliance with limitations listed above must be approved by a design professional. Values herein are based on punchout configuration and location as illustrated below.
8. The 10" end distance shown may be altered if calculations are in conformance with code.

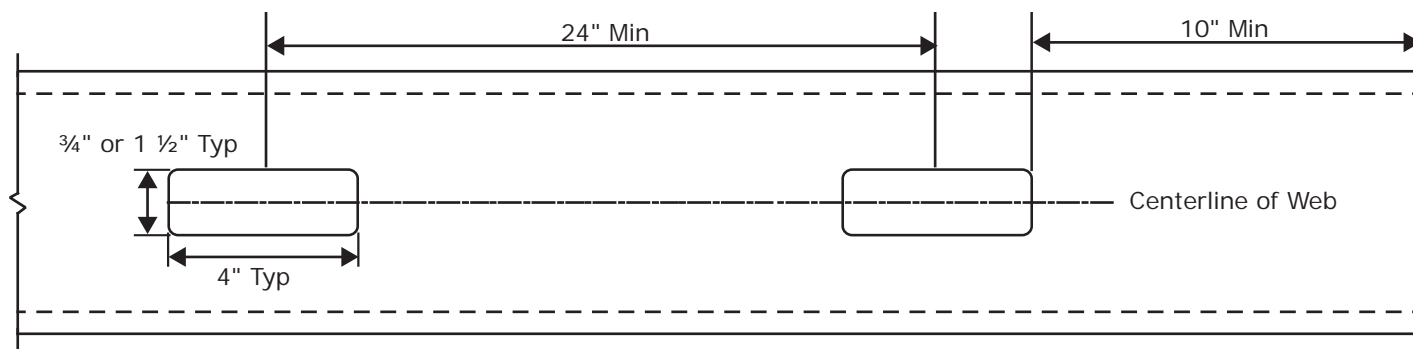

## Steel Thickness and Stiffening Lip Length

Designation Thickness (mil)	Minimum Thickness <sup>1</sup> (in)	Design Thickness <sup>1</sup> (in)	Design Inside Corner Radii (in)	Galvanized Thickness
D25	0.0147	0.0155	0.0860	G40
D20	0.0179	0.0188	0.0844	G40
30EQD	0.0223	0.0235	0.0820	G40
33EQD	0.0223	0.0235	0.0820	G40
33EQS	0.0280	0.0295	0.0790	G60
43EQS	0.0380	0.0400	0.0712	G60

Member	Flange Width	Stiffening Lip Length (in)
S125	1 1/4"	0.300
SFS143	1 7/16"	0.375
SFS162	1 1/8"	0.500
SFS200	2"	0.625

<sup>1</sup>Minimum thickness represents 95% of the design thickness and is the minimum acceptable thickness delivered to the jobsite based on AISI S100-07 Section A2.4

## Screw and Weld Capacities

### Screw Table Notes

- Capacities based on AISI S100 Section E4 specification.
- When connecting materials of different steel thicknesses or tensile strengths, use the lowest values. Tabulated values assume two sheets of equal thickness are connected.
- Capacities are based on Allowable Strength Design (ASD) and include safety factor of 3.0.
- Where multiple fasteners are used, screws are assumed to have a center-to-center spacing of at least 3 times the nominal diameter (d).
- Screws are assumed to have a center-of-screw to edge-of-steel dimension of at least 1.5 times the nominal diameter (d) of the screw.
- Tension capacity is based on the lesser of pull-out capacity in sheet closest to screw tip, or pull-over capacity for sheet closest to screw head (based on head diameter shown).
- For all tension values shown in this table, pull-over values have been reduced by 50 percent assuming eccentrically loaded connections that produce a non-uniform pull-over force on the fastener.
- Values are for pure shear or tension loads. See AISI S100 Section E4.5 for combined shear and pull-over.
- Higher values, especially for screw strength, may be obtained by specifying screws from a specific manufacturer.
- Shear and tension data for screws was developed with the assistance of the Wei-Wen Yu Center for Cold-Formed Steel Structures (CCFSS), using manufacturers' data and evaluation reports available at the time of publication.

### Allowable Screw Connection Capacity (Pounds Per Screw)

Designation Thickness (mil)	Design Thickness	Fy Yield (ksi)	Fu Tensile (ksi)	#6 Screw		#8 Screw		#10 Screw		#12 Screw		¼" Screw	
				0.138" Dia; 0.25" Head		0.164" Dia; 0.313" Head		0.190" Dia; 0.340" Head		0.216" Dia; 0.340" Head		0.250" Dia; 0.409" Head	
				Shear	Tension	Shear	Tension	Shear	Tension	Shear	Tension	Shear	Tension
D25	0.0155	57	65	65	39	150	47	77	54	-	-	-	-
D20	0.0188	57	65	142 <sup>1</sup>	48	150 <sup>1</sup>	57	164 <sup>1</sup>	66	109	75	-	-
30EQD	0.0235	57	65	174 <sup>1</sup>	60	184 <sup>1</sup>	71	236 <sup>1</sup>	82	152	93	-	-
33EQD	0.0235	57	65	174 <sup>1</sup>	60	184 <sup>1</sup>	71	236 <sup>1</sup>	82	152	93	-	-
33EQS	0.0295	57	65	171	75	187	89	201	103	214	117	231	136
43EQS	0.0400	57	65	270	102	295	121	317	140	338	159	364	184

<sup>1</sup>Values are based on testing using AISI S100 procedures.

### Weld Table Notes

- Weld capacities are based the AISI S100 Specification Sections E2.4 for fillet welds and E2.5 for groove welds.
- When connecting materials of different steel thicknesses or tensile strengths (Fu), the lowest values should be used.
- Capacities are based on Allowable Strength Design (ASD) and include appropriate safety factors.
- Weld capacities are based on either 0.938" or 0.125" diameter E60 or E70 electrodes. The use of 0.030" to 0.035" diameter wire electrodes may provide best results.
- Longitudinal capacity is loading in parallel direction of the length of the weld.
- Transverse capacity is loading in perpendicular direction of the length of the weld.
- For flare groove welds, the effective throat of weld is conservatively assumed to be less than 2t.

### Weld Capacity (Pounds Per 1" Weld)

Steel Thickness		Fy (ksi)	Fu (ksi)	Nominal Weld Size	Weld Type			
Mil	Design				Fillet		Flare Groove	
					Longitudinal <sup>1</sup>	Transverse	Longitudinal <sup>2</sup>	Transverse
43EQS	0.0400	57	65	⅙	639	1106	696	849

<sup>1</sup> For welds with L/t > 25 where L is weld length and t is the thickness of the welded member.

<sup>2</sup> For t <= tw < 2t where t = thickness of welded member and tw is effective throat thickness of weld.

## Web Depth-to-Thickness Ratios <sup>2,3,4</sup>

Web Depth-to-Thickness Ratio										
Mil Thickness	D25		D20		30EQD/33EQD		33EQS		43EQS	
Design Thickness (in)	0.0155		0.0188		0.0235		0.0295		0.04	
Inside Bend Radius (in)	0.086		0.0844		0.082		0.079		0.0712	
Depth (in)	h (in)	h/t	h (in)	h/t	h (in)	h/t	h (in)	h/t	h (in)	h/t
1.625	1.422	91	1.419	75	1.414	60	1.408	47	1.403	35
2.5	2.297	148	2.294	122	2.289	97	2.283	77	2.278	56
3.5	3.297	-	3.294	175	3.289	139	3.283	111	3.278	81
3.625	3.422	-	3.419	181	3.414	145	3.408	115	3.403	85
4	3.797	-	3.794	200	3.789	161	3.783	128	3.778	94
5.5	5.297	-	5.294	-	5.289	-	5.283	179	5.278	131
6	5.797	-	5.794	-	5.789	-	5.783	196	5.778	144
8	7.797	-	7.794	-	7.789	-	7.783	-	7.778	194

<sup>1</sup> h/t exceeds 200

<sup>2</sup> h value used for h/t calculation is the flat width of the web. For S members, this is the out-to-out member size, minus twice the thickness, minus twice the inside bend radius.

<sup>3</sup> h/t values exceeding 260 are marked with a dash (-).

<sup>4</sup> h/t values in this table apply to S (studs and joists) members only and do not apply to tracks and channels.

## Definitions of Section Property Symbols

### Gross Properties

- I<sub>x</sub>: Moment of inertia of the cross section about the x-axis.
- S<sub>x</sub>: Section modulus about the x-axis.
- R<sub>x</sub>: Radius of gyration of cross section about the x-axis.
- I<sub>y</sub>: Moment of inertia of cross section about the y-axis.
- R<sub>y</sub>: Radius of gyration of cross section about the y-axis.

### Effective Properties

- I<sub>x</sub>: Effective moment of inertia about the x-axis.
- S<sub>xe</sub>: Effective section modulus about the x-axis.
- M<sub>al</sub>: Allowable moment based on local buckling.
- M<sub>ad</sub>: Allowable moment based on distortional buckling, assuming Kφ = 0.
- M<sub>a</sub>: Allowable moment for track and channel members, based on local buckling only.
- V<sub>ag</sub>: Allowable strong axis shear away from punchout, calculated in accordance with AISI S100 Section C3.2.1.
- V<sub>anet</sub>: Allowable strong axis shear at the punchout, calculated in accordance with AISI S100 Section C3.2.2.

### Torsional and Other Properties

- J: St. Venant torsional constant. The numbers shown in the tables for J have been multiplied by 1000. The actual values can be obtained by dividing the listed numbers by 1000.
- C<sub>w</sub>: Torsional warping constant.
- X<sub>o</sub>: Distance from the shear center to the centroid along the principal x-axis.
- m: Distance from shear center to mid-plane of web.
- R<sub>o</sub>: Polar radius of gyration of cross section about the shear center.
- β: 1 - (X<sub>o</sub>/R<sub>o</sub>)<sup>2</sup>
- L<sub>u</sub>: Critical unbraced length for lateral-torsional buckling. Members are considered fully braced when unbraced length is less than L<sub>u</sub>.
- Kφ: Distortional buckling moment (M<sub>ad</sub>) is calculated without the beneficial effect of sheathing to rotational stiffness. Kφ = 0.

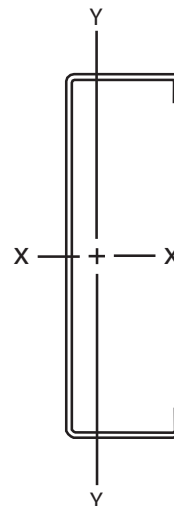

# Section Properties - Nonstructural Studs

## Table Notes

1. The centerline bend radius is based on inside corner radii shown in the steel thickness table on page 5.
2. Effective properties incorporate the strength increase from the cold work of forming as applicable per AISI S100 Section A7.2.
3. Tabulated gross properties are based on the full-unreduced cross section of the studs away from punchouts.
4. For deflection calculations, use the effective moment of inertia.
5. Allowable moment is the lesser of  $M_{al}$  and  $M_{ad}$ . Stud distortional buckling is based on an assumed  $K\phi = 0$ .
6. See page 5 for additional table notes.

## Nonstructural Supreme Studs (SFS) - Section Properties

Part No.	Design Thickness (in)	Fy (ksi)	Gross Properties							Effective Properties						Torsional Properties					Lu (in)	
			Area (in <sup>2</sup> )	Weight (lb/ft)	Ix (in <sup>4</sup> )	Sx (in <sup>3</sup> )	Rx (in)	Iy (in <sup>4</sup> )	Ry (in)	Ixe (in <sup>4</sup> )	Sxe (in <sup>3</sup> )	Mal (in-k)	Mad (in-k)	Vag (lb)	VaNet (lb)	Jx1000 (in <sup>4</sup> )	Cw (in <sup>6</sup> )	Xo (in)	m (in)	Ro (in)		β
162SFS125-D25	0.0155	57	0.07	0.24	0.033	0.04	0.682	0.015	0.47	0.031	-	0.66	0.73	233	94	0.006	0.011	-1.13	0.65	1.4	0.35	24.4
162SFS-D20	0.0188	57	0.094	0.32	0.044	0.055	0.686	0.028	0.545	0.043	0.033	0.95	1.08	397	131	0.011	0.022	-1.365	0.779	1.622	0.292	29.1
162SFS-30EQD	0.0235	57	0.117	0.4	0.055	0.068	0.684	0.035	0.543	0.052	0.048	1.63	1.7	621	162	0.022	0.027	-1.359	0.776	1.616	0.292	29
162SFS-33EQD	0.0235	57	0.117	0.4	0.055	0.068	0.684	0.035	0.543	0.052	0.048	1.63	1.7	621	162	0.022	0.027	-1.359	0.776	1.616	0.292	29
250SFS125-D25	0.0155	57	0.083	0.28	0.086	0.068	1.015	0.018	0.465	0.079	-	1.26	1.16	144	133	0.007	0.025	-0.99	0.59	1.49	0.56	24
250SFS-D20	0.0188	57	0.111	0.38	0.117	0.093	1.027	0.033	0.545	0.112	0.06	1.75	1.72	258	196	0.013	0.049	-1.217	0.719	1.683	0.477	28.1
250SFS-30EQD	0.0235	57	0.138	0.47	0.145	0.116	1.025	0.041	0.542	0.136	0.09	3.06	2.68	505	306	0.025	0.06	-1.212	0.716	1.677	0.478	28
250SFS-33EQD	0.0235	57	0.138	0.47	0.145	0.116	1.025	0.041	0.542	0.136	0.09	3.06	2.68	505	306	0.025	0.06	-1.212	0.716	1.677	0.478	28
350SFS125-D25	0.0155	57	0.099	0.34	0.186	0.106	1.373	0.02	0.451	0.166	-	1.75	1.66	-	-	0.008	0.051	-0.88	0.54	1.69	0.73	23.6
350SFS-D20	0.0188	57	0.13	0.44	0.252	0.144	1.395	0.037	0.533	0.235	0.077	2.4	2.47	180	159	0.015	0.097	-1.088	0.662	1.847	0.653	27.6
350SFS-30EQD	0.0235	57	0.161	0.55	0.313	0.179	1.392	0.046	0.531	0.304	0.112	3.83	3.84	351	248	0.03	0.119	-1.083	0.659	1.842	0.655	27.6
350SFS-33EQD	0.0235	57	0.161	0.55	0.313	0.179	1.392	0.046	0.531	0.304	0.112	3.83	3.84	351	248	0.03	0.119	-1.083	0.659	1.842	0.655	27.6
362SFS125-D25	0.0155	57	0.101	0.34	0.202	0.111	1.416	0.02	0.449	0.18	-	1.84	1.72	-	-	0.008	0.055	-0.87	0.54	1.72	0.75	23.6
362SFS-D20	0.0188	57	0.132	0.45	0.273	0.151	1.439	0.037	0.531	0.254	0.08	2.52	2.56	173	164	0.016	0.104	-1.074	0.655	1.873	0.671	27.6
362SFS-30EQD	0.0235	57	0.164	0.56	0.339	0.187	1.437	0.046	0.529	0.331	0.116	3.97	3.98	338	255	0.03	0.128	-1.069	0.652	1.867	0.672	27.5
362SFS-33EQD	0.0235	57	0.164	0.56	0.339	0.187	1.437	0.046	0.529	0.331	0.116	3.97	3.98	338	255	0.03	0.128	-1.069	0.652	1.867	0.672	27.5
400SFS125-D25	0.0155	57	0.107	0.36	0.255	0.127	1.545	0.021	0.443	0.223	-	2.1	1.9	-	-	0.009	0.069	-0.83	0.52	1.81	0.79	23.4
400SFS-D20 <sup>1</sup>	0.0188	57	0.139	0.47	0.343	0.172	1.572	0.038	0.526	0.314	0.087	2.86	2.84	156	156	0.016	0.129	-1.034	0.637	1.954	0.72	27.5
400SFS-30EQD	0.0235	57	0.173	0.59	0.427	0.213	1.569	0.047	0.524	0.417	0.129	4.4	4.41	305	275	0.032	0.159	-1.029	0.634	1.949	0.721	27.4
400SFS-33EQD	0.0235	57	0.173	0.59	0.427	0.213	1.569	0.047	0.524	0.417	0.129	4.4	4.41	305	275	0.032	0.159	-1.029	0.634	1.949	0.721	27.4
550SFS125-D25	0.0155	57	0.13	0.44	0.543	0.198	2.045	0.023	0.419	-	-	-	-	-	-	0.01	0.14	-0.715	0.47	2.207	0.9	-
550SFS-D20 <sup>2</sup>	0.0188	57	0.167	0.57	0.726	0.264	2.084	0.042	0.502	-	-	-	-	-	-	0.02	0.259	-0.904	0.574	2.327	0.894	-
550SFS-30EQD <sup>1</sup>	0.0235	57	0.208	0.71	0.903	0.328	2.081	0.052	0.5	0.896	0.204	6.97	6.09	218	218	0.038	0.32	-0.9	0.571	2.322	0.85	26.9
550SFS-33EQD <sup>1</sup>	0.0235	57	0.208	0.71	0.903	0.328	2.081	0.052	0.5	0.896	0.204	6.97	6.09	218	218	0.038	0.32	-0.9	0.571	2.322	0.85	26.9
600SFS125-D25	0.0155	57	0.138	0.47	0.67	0.224	2.207	0.023	0.411	-	-	-	-	-	-	0.011	0.17	-0.685	0.45	2.347	0.92	-
600SFS-D20 <sup>2</sup>	0.0188	57	0.177	0.6	0.894	0.298	2.25	0.043	0.494	-	-	-	-	-	-	0.021	0.314	-0.869	0.556	2.462	0.875	-
600SFS-30EQD <sup>1</sup>	0.0235	57	0.22	0.75	1.112	0.371	2.247	0.053	0.492	0.976	0.219	7.46	6.6	200	200	0.041	0.388	-0.864	0.553	2.457	0.876	26.7
600SFS-33EQD <sup>1</sup>	0.0235	57	0.22	0.75	1.112	0.371	2.247	0.053	0.492	0.976	0.219	7.46	6.6	200	200	0.041	0.388	-0.864	0.553	2.457	0.876	26.7

<sup>1</sup>Web height-to-thickness ratio exceeds 200. Web stiffeners are required at all support points and concentrated loads.

<sup>2</sup>Web height-to-thickness ratio exceeds 260. Section is not in compliance with AISI S100 Section B1, but may be used in accordance with SSFSA's published composite wall data for these members.



## Table Notes

1. The centerline bend radius is based on inside corner radii shown in the steel thickness table on page 5.
2. Effective properties incorporate the strength increase from the cold work of forming as applicable per AISI S100 Section A7.2.
3. Tabulated gross properties are based on the full-unreduced cross section of the studs away from punchouts.
4. For deflection calculations, use the effective moment of inertia.
5. Allowable moment is the lesser of  $M_{ol}$  and  $M_{od}$ . Stud distortional buckling is based on an assumed  $K\phi = 0$ .
6. See page 5 for additional table notes.

Structural Supreme Studs (SFS) - Section Properties																						
Part No.	Design Thickness (in)	Fy (ksi)	Gross Properties						Effective Properties						Torsional Properties						Lu (in)	
			Area (in <sup>2</sup> )	Weight (lb/ft)	Ix (in <sup>4</sup> )	Sx (in <sup>3</sup> )	Rx (in)	Iy (in <sup>4</sup> )	Ry (in)	Ixe (in <sup>4</sup> )	Sxe (in <sup>3</sup> )	Mal (in-k)	Mad (in-k)	Vag (lb)	VaNet (lb)	Jx1000 (in <sup>4</sup> )	Cw (in <sup>6</sup> )	Xo (in)	m (in)	Ro (in)		β
250SFS162-33EQS	0.0295	57	0.191	0.65	0.202	0.162	1.029	0.075	0.626	0.195	0.134	4.57	4.17	978	471	0.055	0.127	-1.475	0.863	1.905	0.400	33.4
250SFS162-43EQS	0.0400	57	0.257	0.88	0.270	0.216	1.025	0.100	0.622	0.270	0.185	6.32	6.26	1798	636	0.137	0.166	-1.463	0.856	1.892	0.402	33.4
250SFS200-43EQS	0.0400	57	0.297	1.01	0.320	0.256	1.038	0.177	0.771	0.311	0.215	7.34	7.14	1798	636	0.159	0.344	-1.920	1.104	2.315	0.312	39.4
350SFS162-33EQS	0.0295	57	0.220	0.75	0.436	0.249	1.407	0.085	0.619	0.425	0.179	6.10	6.02	696	390	0.064	0.239	-1.330	0.799	2.032	0.572	32.5
350SFS162-43EQS	0.0400	57	0.297	1.01	0.585	0.334	1.402	0.112	0.615	0.585	0.257	8.78	9.12	1738	715	0.159	0.315	-1.318	0.792	2.020	0.574	32.3
350SFS200-43EQS	0.0400	57	0.337	1.15	0.688	0.393	1.429	0.200	0.771	0.675	0.301	10.28	10.33	1738	715	0.180	0.617	-1.754	1.035	2.389	0.461	38.4
362SFS162-33EQS	0.0295	57	0.224	0.76	0.473	0.261	1.452	0.086	0.618	0.462	0.186	6.34	6.25	670	402	0.065	0.257	-1.314	0.792	2.054	0.591	32.4
362SFS162-43EQS	0.0400	57	0.302	1.03	0.634	0.350	1.448	0.114	0.613	0.634	0.267	9.12	9.48	1674	737	0.161	0.338	-1.302	0.785	2.042	0.593	32.3
362SFS200-43EQS	0.0400	57	0.342	1.16	0.746	0.412	1.476	0.203	0.770	0.732	0.314	10.70	10.74	1674	737	0.183	0.659	-1.735	1.027	2.404	0.479	38.4
400SFS162-33EQS	0.0295	57	0.235	0.80	0.593	0.297	1.589	0.088	0.613	0.581	0.206	7.04	6.95	604	433	0.068	0.314	-1.269	0.771	2.124	0.643	32.2
400SFS162-43EQS	0.0400	57	0.317	1.08	0.796	0.398	1.584	0.118	0.609	0.796	0.298	10.16	10.57	1508	795	0.169	0.413	-1.258	0.765	2.112	0.645	32.0
400SFS200-43EQS	0.0400	57	0.357	1.22	0.935	0.467	1.617	0.210	0.767	0.919	0.350	11.94	11.96	1508	795	0.191	0.795	-1.682	1.004	2.456	0.531	38.2
550SFS162-33EQS	0.0295	57	0.279	0.95	1.249	0.454	2.115	0.098	0.591	1.235	0.333	11.36	9.72	433	433	0.081	0.615	-1.119	0.700	2.464	0.794	31.5
550SFS162-43EQS	0.0400	57	0.377	1.28	1.679	0.611	2.110	0.130	0.587	1.679	0.515	17.59	14.95	1079	944	0.201	0.813	-1.108	0.694	2.454	0.796	31.3
550SFS200-43EQS	0.0400	57	0.417	1.42	1.951	0.709	2.162	0.234	0.748	1.933	0.589	20.10	16.90	1079	944	0.223	1.516	-1.502	0.921	2.737	0.699	37.7
600SFS162-33EQS	0.0295	57	0.294	1.00	1.535	0.512	2.285	0.100	0.583	1.522	0.363	12.38	10.62	395	395	0.085	0.743	-1.078	0.680	2.592	0.827	31.3
600SFS162-43EQS	0.0400	57	0.397	1.35	2.065	0.688	2.280	0.133	0.579	2.065	0.559	19.08	16.37	986	976	0.212	0.983	-1.067	0.673	2.583	0.829	31.1
600SFS200-43EQS	0.0400	57	0.437	1.49	2.390	0.797	2.338	0.240	0.741	2.374	0.640	21.85	18.54	986	976	0.233	1.822	-1.452	0.897	2.850	0.741	37.5
800SFS162-43EQS	0.0400	57	0.477	1.62	4.128	1.032	2.941	0.143	0.548	3.870	0.706	24.11	21.67	732	732	0.255	1.862	-0.931	0.603	3.133	0.912	30.4
800SFS200-43EQS	0.0400	57	0.517	1.76	4.721	1.180	3.021	0.261	0.710	4.721	0.848	28.94	24.89	732	732	0.276	3.400	-1.283	0.814	3.358	0.854	36.9





# Composite Interior Wall Heights

## Table Notes

1. Allowable composite limiting heights are calculated using ICC-ES AC86-2010. The  $\frac{1}{3}$  stress increase for strength was not used.
2. No fasteners are required for attaching the stud to the track.
3. Stud bearing must be a minimum of 1".
4. The gypsum board must be applied full height in the vertical orientation to each stud flange and installed using minimum #6 Type S drywall screws.
5. Galvanizing to be G40 minimum for 10 PSF or less, and G60 minimum for greater than 10 PSF lateral loads.

Composite Interior Wall Heights														
Part No.	Fy (ksi)	Spacing (in) oc	5 psf			7.5 psf			10 psf			15 psf		
			L/120	L/240	L/360	L/120	L/240	L/360	L/120	L/240	L/360	L/120	L/240	L/360
162SFS-125-D25	57	12	13' 4"	10' 10"	9' 8"	11' 8"	9' 7"	8' 6"	10' 7"	8' 9"	-	-	-	-
	57	16	12' 1"	9' 12"	8' 10"	10' 7"	8' 9"	-	9' 7"	7' 11"	-	-	-	-
	57	24	10' 7"	8' 9"	-	9' 3"	-	-	8' 2" f	-	-	-	-	-
250SFS-125-D25	57	12	15' 8"	13' 7"	12' 2"	13' 8"	11' 11"	10' 7"	12' 5"	10' 10"	9' 7"	8' 5" f	8' 5" f	8' 1"
	57	16	14' 3"	12' 4"	11' 0"	12' 5"	10' 10"	9' 7"	11' 1" f	9' 10"	8' 6"	-	-	-
	57	24	12' 5"	10' 10"	9' 7"	10' 5" f	9' 4"	8' 1"	9' 0" f	8' 4"	-	-	-	-
362SFS-125-D25	57	12	21' 9"	17' 3"	15' 1"	18' 6" f	15' 1"	13' 2"	16' 1" f	13' 9"	12' 0"	10' 7" f	10' 7" f	10' 4"
	57	16	19' 8" f	15' 8"	13' 9"	16' 1" f	13' 9"	12' 0"	13' 11" f	12' 6"	10' 9"	9' 2" f	9' 2" f	9' 2" f
	57	24	16' 1" f	13' 9"	12' 0"	13' 1" f	12' 0"	10' 4"	11' 4" f	10' 9"	9' 3"	-	-	-
400SFS-125-D25	57	12	21' 8"	17' 7"	15' 8"	18' 6" f	15' 4"	13' 9"	16' 0" f	14' 0"	12' 6"	10' 6" f	10' 6" f	10' 6" f
	57	16	19' 7" f	16' 0"	14' 3"	16' 0" f	14' 0"	12' 6"	13' 10" f	12' 8"	11' 4"	9' 1" f	9' 1" f	9' 1" f
	57	24	16' 0" f	14' 0"	12' 6"	13' 1" f	12' 2"	10' 11"	11' 4" f	11' 1"	9' 11"	-	-	-
600SFS-125-D25	57	12	28' 8" f	24' 4"	21' 7"	23' 5" f	21' 3"	18' 10"	20' 3" f	19' 3"	17' 2"	13' 4" f	13' 4" f	13' 4" f
	57	16	24' 10" f	22' 1"	19' 8"	20' 3" f	19' 3"	17' 2"	17' 7"	17' 6"	15' 7"	-	-	-
	57	24	20' 3" f	19' 3"	17' 2"	16' 7" f	16' 7" f	14' 11"	14' 4" f	14' 4" f	13' 5"	-	-	-
162SFS-D20	57	12	13' 7"	11' 1"	9' 9"	11' 11"	9' 9"	8' 6"	10' 10"	8' 10"	7' 9"	8' 2" f	7' 9"	-
	57	16	12' 4"	10' 1"	8' 10"	10' 10"	8' 10"	7' 9"	9' 10"	8' 1"	-	-	-	-
	57	24	10' 10"	8' 10"	7' 9"	9' 5"	7' 9"	-	8' 5"	-	-	-	-	-
250SFS-D20	57	12	17' 1"	14' 0"	12' 5"	14' 11"	12' 3"	10' 10"	13' 7"	11' 1"	9' 10"	9' 5" f	9' 5" f	8' 2"
	57	16	15' 6"	12' 9"	11' 3"	13' 7"	11' 1"	9' 10"	12' 4"	10' 1"	8' 8"	8' 2" f	8' 2" f	-
	57	24	13' 7"	11' 1"	9' 10"	11' 8" f	9' 8"	8' 2"	10' 2" f	8' 7"	-	-	-	-
362SFS-D20	57	12	22' 4"	17' 9"	15' 6"	19' 6"	15' 6"	13' 7"	17' 3" f	14' 1"	12' 4"	11' 4" f	11' 4" f	10' 8"
	57	16	20' 4"	16' 1"	14' 1"	17' 3" f	14' 1"	12' 4"	15' 0" f	12' 10"	11' 1"	9' 10" f	9' 10" f	9' 7"
	57	24	17' 3" f	14' 1"	12' 4"	14' 1" f	12' 4"	10' 8"	12' 3" f	11' 1"	9' 7"	8' 0" f	8' 0" f	8' 0" f
400SFS-D20	57	12	23' 1"	18' 4"	16' 0"	20' 2"	16' 0"	14' 0"	17' 8" f	14' 6"	12' 8"	11' 7" f	11' 7" f	11' 1"
	57	16	21' 0"	16' 8"	14' 6"	17' 8" f	14' 6"	12' 8"	15' 3" f	13' 2"	11' 6"	10' 0" f	10' 0" f	10' 0"
	57	24	17' 8" f	14' 6"	12' 8"	14' 5" f	12' 8"	11' 1"	12' 6" f	11' 6"	10' 0"	8' 2" f	8' 2" f	8' 2" f
600SFS-D20	57	12	31' 2"	24' 9"	21' 7"	25' 11" f	21' 7"	18' 10"	22' 6" f	19' 7"	17' 2"	14' 9" f	14' 9" f	14' 9" f
	57	16	27' 6" f	22' 6"	19' 7"	22' 6" f	19' 7"	17' 2"	19' 6" f	17' 10"	15' 7"	12' 9" f	12' 9" f	12' 9" f
	57	24	22' 6" f	19' 7"	17' 2"	18' 4" f	17' 2"	14' 10"	15' 11" f	15' 7"	13' 4"	-	-	-
162SFS-30EQD	57	12	13' 11"	11' 4"	10' 0"	12' 2"	9' 11"	8' 8"	11' 0"	9' 0"	7' 10"	8' 7" f	7' 9"	-
	57	16	12' 8"	10' 4"	9' 1"	11' 0"	9' 0"	7' 10"	10' 0"	8' 1"	-	-	-	-
	57	24	11' 0"	9' 0"	7' 10"	9' 7"	7' 9"	-	8' 6"	-	-	-	-	-
250SFS-30EQD	57	12	18' 2"	14' 5"	12' 7"	15' 10"	12' 7"	11' 0"	14' 5"	11' 5"	10' 0"	10' 3" f	10' 0"	8' 6"
	57	16	16' 6"	13' 1"	11' 5"	14' 5"	11' 5"	10' 0"	13' 1"	10' 5"	8' 11"	8' 11" f	8' 11" f	-
	57	24	14' 5"	11' 5"	10' 0"	12' 7"	10' 0"	8' 6"	11' 0" f	8' 11"	-	-	-	-
362SFS-30EQD	57	12	23' 6"	18' 8"	16' 4"	20' 6"	16' 4"	14' 3"	18' 8"	14' 10"	12' 11"	12' 6" f	12' 6" f	11' 3"
	57	16	21' 4"	16' 11"	14' 10"	18' 8"	14' 10"	12' 11"	16' 5" f	13' 5"	11' 9"	10' 10" f	10' 10" f	10' 2"
	57	24	18' 8"	14' 10"	12' 11"	15' 6" f	12' 11"	11' 3"	13' 5" f	11' 9"	10' 2"	8' 10" f	8' 10" f	8' 9"
400SFS-30EQD	57	12	25' 0"	19' 10"	17' 4"	21' 10"	17' 4"	15' 2"	19' 8" f	15' 9"	13' 9"	12' 11" f	12' 11" f	12' 0"
	57	16	22' 9"	18' 1"	15' 9"	19' 8" f	15' 9"	13' 9"	17' 0" f	14' 4"	12' 6"	11' 2" f	11' 2" f	10' 11"
	57	24	19' 8" f	15' 9"	13' 9"	16' 0" f	13' 9"	12' 0"	13' 11" f	12' 6"	10' 11"	9' 2" f	9' 2" f	9' 2" f
600SFS-30EQD	57	12	33' 8"	26' 9"	23' 4"	28' 4" f	23' 4"	20' 5"	24' 6" f	21' 2"	18' 6"	16' 1" f	16' 1" f	16' 1" f
	57	16	30' 0" f	24' 3"	21' 2"	24' 6" f	21' 2"	18' 6"	21' 3" f	19' 3"	16' 10"	13' 11" f	13' 11" f	13' 11" f
	57	24	24' 6" f	21' 2"	18' 6"	20' 0" f	18' 6"	16' 2"	17' 4" f	16' 10"	14' 8"	-	-	-
162SFS-33EQD	57	12	13' 11"	11' 4"	10' 0"	12' 2"	9' 11"	8' 8"	11' 0"	9' 0"	7' 10"	8' 7" f	7' 9"	-
	57	16	12' 8"	10' 4"	9' 1"	11' 0"	9' 0"	7' 10"	10' 0"	8' 1"	-	-	-	-
	57	24	11' 0"	9' 0"	7' 10"	9' 7"	7' 9"	-	8' 6"	-	-	-	-	-
250SFS-33EQD	57	12	18' 2"	14' 5"	12' 7"	15' 10"	12' 7"	11' 0"	14' 5"	11' 5"	10' 0"	10' 3" f	10' 0"	8' 6"
	57	16	16' 6"	13' 1"	11' 5"	14' 5"	11' 5"	10' 0"	13' 1"	10' 5"	8' 11"	8' 11" f	8' 11" f	-
	57	24	14' 5"	11' 5"	10' 0"	12' 7"	10' 0"	8' 6"	11' 0" f	8' 11"	-	-	-	-
362SFS-33EQD	57	12	23' 6"	18' 8"	16' 4"	20' 6"	16' 4"	14' 3"	18' 8"	14' 10"	12' 11"	12' 6" f	12' 6" f	11' 3"
	57	16	21' 4"	16' 11"	14' 10"	18' 8"	14' 10"	12' 11"	16' 5" f	13' 5"	11' 9"	10' 10" f	10' 10" f	10' 2"
	57	24	18' 8"	14' 10"	12' 11"	15' 6" f	12' 11"	11' 3"	13' 5" f	11' 9"	10' 2"	8' 10" f	8' 10" f	8' 9"
400SFS-33EQD	57	12	25' 0"	19' 10"	17' 4"	21' 10"	17' 4"	15' 2"	19' 8" f	15' 9"	13' 9"	12' 11" f	12' 11" f	12' 0"
	57	16	22' 9"	18' 1"	15' 9"	19' 8" f	15' 9"	13' 9"	17' 0" f	14' 4"	12' 6"	11' 2" f	11' 2" f	10' 11"
	57	24	19' 8" f	15' 9"	13' 9"	16' 0" f	13' 9"	12' 0"	13' 11" f	12' 6"	10' 11"	9' 2" f	9' 2" f	9' 2" f
600SFS-33EQD	57	12	33' 8"	26' 9"	23' 4"	28' 4" f	23' 4"	20' 5"	24' 6" f	21' 2"	18' 6"	16' 1" f	16' 1" f	16' 1" f
	57	16	30' 0" f	24' 3"	21' 2"	24' 6" f	21' 2"	18' 6"	21' 3" f	19' 3"	16' 10"	13' 11" f	13' 11" f	13' 11" f
	57	24	24' 6" f	21' 2"	18' 6"	20' 0" f	18' 6"	16' 2"	17' 4" f	16' 10"	14' 8"	-	-	-

"F" Flexural stress controls allowable height.

## Table Notes

1. 5 pounds per square foot (psf), 7.5 psf, and 10 psf loads have **not** been reduced for strength or deflection checks; full lateral load is applied.
2. Limiting heights are based on steel properties only (non-composite) without the contribution of sheathing to strengthen and stiffen the assembly. Properly fastened sheathing is still required for members to be considered fully braced.
3. Web crippling check is based on 1" end bearing.
4. Allowable moment is the lesser of  $M_{sl}$  and  $M_{sd}$ . Stud distortional buckling based on an assumed  $K\phi = 0$ .
5. See page 5 for additional table notes.

Non-Composite - Fully Braced											
Part No.	F <sub>y</sub> (ksi)	Spacing (in) oc	5 psf			7.5 psf			10 psf		
			L/120	L/240	L/360	L/120	L/240	L/360	L/120	L/240	L/360
162 SFS125-D25	57	12	9' 4"	-	-	-	-	-	-	-	-
	57	16	8' 1"	-	-	-	-	-	-	-	-
	57	24	-	-	-	-	-	-	-	-	-
250 SFS125-D25	57	12	12' 10"	10' 2"	8' 11"	10' 6"	8' 11"	-	9' 1"	8' 1"	-
	57	16	11' 2"	9' 3"	8' 1"	9' 1"	8' 1"	-	-	-	-
	57	24	9' 1"	8' 1"	-	-	-	-	-	-	-
350 SFS125-D25	57	12	14' 4"	12' 11"	11' 3"	11' 8"	11' 3"	9' 10"	10' 1"	10' 1"	8' 11"
	57	16	12' 5"	11' 9"	10' 3"	10' 1"	10' 1"	8' 11"	8' 9" 1	8' 9" 1	8' 1"
	57	24	10' 1"	10' 1"	8' 11"	8' 3" 1	8' 3" 1	-	-	-	-
362 SFS125-D25	57	12	14' 6"	13' 5"	11' 9"	11' 10"	11' 8"	10' 3"	10' 3"	10' 3"	9' 4"
	57	16	12' 7"	12' 2"	10' 8"	10' 3"	10' 3"	9' 4"	8' 11" 1	8' 11" 1	8' 5"
	57	24	10' 3"	10' 3"	9' 4"	8' 5" 1	8' 5" 1	8' 1" 1	-	-	-
400 SFS125-D25	57	12	15' 0"	14' 1"	12' 4"	12' 3"	12' 3"	10' 9"	10' 7"	10' 7"	9' 9"
	57	16	13' 0"	12' 10"	11' 2"	10' 7"	10' 7"	9' 9"	9' 2" 1	9' 2" 1	8' 10" 1
	57	24	10' 7"	10' 7"	9' 9"	8' 8" 1	8' 8" 1	8' 6" 1	-	-	-
162SFS-D20	57	12	10' 5"	8' 3"	-	9' 1"	-	-	-	-	-
	57	16	9' 5"	-	-	-	-	-	-	-	-
	57	24	-	-	-	-	-	-	-	-	-
250SFS-D20	57	12	14' 4"	11' 4"	9' 11"	12' 4"	9' 11"	8' 8"	10' 8"	9' 0"	-
	57	16	13' 0"	10' 4"	9' 0"	10' 8"	9' 0"	-	9' 3"	8' 2"	-
	57	24	10' 8"	9' 0"	-	8' 9"	-	-	-	-	-
350SFS-D20	57	12	17' 11"	14' 7"	12' 8"	14' 7"	12' 8"	11' 1"	12' 8"	11' 7"	10' 1"
	57	16	15' 6"	13' 3"	11' 7"	12' 8"	11' 7"	10' 1"	10' 11"	10' 6"	9' 2"
	57	24	12' 8"	11' 7"	10' 1"	10' 4"	10' 1"	8' 10"	8' 11"e	8' 11"e	8' 0"
362SFS-D20	57	12	18' 4"	15' 2"	13' 3"	14' 11"	13' 2"	11' 7"	12' 11"	11' 11"	10' 6"
	57	16	15' 10"	13' 9"	12' 0"	12' 11"	11' 11"	10' 6"	11' 3"	10' 9"	9' 7"
	57	24	12' 11"	11' 11"	10' 6"	10' 7"	10' 4"	9' 2"	9' 2"e	9' 2"e	8' 3"
400SFS-D20	57	12	19' 5"	16' 0"	14' 0"	15' 11"	14' 0"	12' 3"	13' 9"	12' 9"	11' 1"
	57	16	16' 10"	14' 7"	12' 9"	13' 9"	12' 9"	11' 1"	11' 11"	11' 7"	10' 1"
	57	24	13' 9"	12' 9"	11' 1"	11' 3"e	11' 1"e	9' 8"	9' 8"	9' 9"e	8' 10"e
162SFS-30EQD	57	12	11' 0"	8' 9"	-	9' 8"	-	-	8' 9"	-	-
	57	16	10' 0"	-	-	8' 9"	-	-	-	-	-
	57	24	8' 9"	-	-	-	-	-	-	-	-
250SFS-30EQD	57	12	15' 4"	12' 2"	10' 7"	13' 5"	10' 7"	9' 3"	12' 2"	9' 8"	8' 5"
	57	16	13' 11"	11' 1"	9' 8"	12' 2"	9' 8"	8' 5"	11' 1"	8' 9"	-
	57	24	12' 2"	9' 8"	8' 5"	10' 7"	8' 5"	-	9' 5"	-	-
350SFS-30EQD	57	12	19' 11"	15' 10"	13' 10"	17' 5"	13' 10"	12' 1"	15' 10"	12' 7"	10' 11"
	57	16	18' 1"	14' 4"	12' 7"	15' 10"	12' 7"	10' 11"	13' 9"	11' 5"	9' 11"
	57	24	15' 10"	12' 7"	10' 11"	13' 0"	10' 11"	9' 7"	11' 3"	9' 11"	8' 8"
362SFS-30EQD	57	12	20' 6"	16' 3"	14' 2"	17' 11"	14' 2"	12' 5"	16' 3"	12' 11"	11' 3"
	57	16	18' 7"	14' 9"	12' 11"	16' 3"	12' 11"	11' 3"	14' 1"	11' 9"	10' 3"
	57	24	16' 3"	12' 11"	11' 3"	13' 3"	11' 3"	9' 10"	11' 6"	10' 3"	8' 11"
400SFS-30EQD	57	12	22' 2"	17' 7"	15' 4"	19' 4"	15' 4"	13' 5"	17' 1"	13' 11"	12' 2"
	57	16	20' 2"	16' 0"	13' 11"	17' 1"	13' 11"	12' 2"	14' 10"	12' 8"	11' 1"
	57	24	17' 1"	13' 11"	12' 2"	13' 11"	12' 2"	10' 8"	12' 1"	11' 1"	9' 8"
550SFS-30EQD <sup>1</sup>	57	12	28' 5"	22' 8"	19' 10"	23' 3"	19' 10"	17' 4"	20' 1"	18' 0"	15' 9"
	57	16	24' 8"	20' 7"	18' 0"	20' 1"	18' 0"	15' 9"	17' 5"	16' 4"	14' 3"
	57	24	20' 1"	18' 0"	15' 9"	16' 5"	15' 9"	13' 9"	14' 2"	14' 2"	12' 6"
600SFS-30EQD <sup>1</sup>	57	12	29' 8"	23' 7"	20' 8"	24' 2"	20' 8"	18' 0"	20' 11"	18' 9"	16' 4"
	57	16	25' 8"	21' 5"	18' 9"	20' 11"	18' 9"	16' 4"	18' 2"	17' 0"	14' 10"
	57	24	20' 11"	18' 9"	16' 4"	17' 1"	16' 4"	14' 3"	14' 10"	14' 10"	13' 0"

<sup>1</sup>Web height-to-thickness ratio exceeds 200. Web stiffeners are required at all support points and concentrated loads.  
"e" Web stiffeners required at ends.

Continued on page 14

# Non-Composite Interior Wall Heights

Non-Composite - Fully Braced											
Part No.	F <sub>y</sub> (ksi)	Spacing (in) oc	5 psf			7.5 psf			10 psf		
			L/120	L/240	L/360	L/120	L/240	L/360	L/120	L/240	L/360
162SFS-33EQD	57	12	11' 0"	8' 9"	-	9' 8"	-	-	8' 9"	-	-
	57	16	10' 0"	-	-	8' 9"	-	-	-	-	-
	57	24	8' 9"	-	-	-	-	-	-	-	-
250SFS-33EQD	57	12	15' 4"	12' 2"	10' 7"	13' 5"	10' 7"	9' 3"	12' 2"	9' 8"	8' 5"
	57	16	13' 11"	11' 1"	9' 8"	12' 2"	9' 8"	8' 5"	11' 1"	8' 9"	-
	57	24	12' 2"	9' 8"	8' 5"	10' 7"	8' 5"	-	9' 5"	-	-
350SFS-33EQD	57	12	19' 11"	15' 10"	13' 10"	17' 5"	13' 10"	12' 1"	15' 10"	12' 7"	10' 11"
	57	16	18' 1"	14' 4"	12' 7"	15' 10"	12' 7"	10' 11"	13' 9"	11' 5"	9' 11"
	57	24	15' 10"	12' 7"	10' 11"	13' 0"	10' 11"	9' 7"	11' 3"	9' 11"	8' 8"
362SFS-33EQD	57	12	22' 2"	17' 7"	15' 4"	19' 4"	15' 4"	13' 5"	17' 1"	13' 11"	12' 2"
	57	16	20' 2"	16' 0"	13' 11"	17' 1"	13' 11"	12' 2"	14' 10"	12' 8"	11' 1"
	57	24	17' 1"	13' 11"	12' 2"	13' 11"	12' 2"	10' 8"	12' 1"	11' 1"	9' 8"
400SFS-33EQD	57	12	22' 2"	17' 7"	15' 4"	19' 4"	15' 4"	13' 5"	17' 1"	13' 11"	12' 2"
	57	16	20' 2"	16' 0"	13' 11"	17' 1"	13' 11"	12' 2"	14' 10"	12' 8"	11' 1"
	57	24	17' 1"	13' 11"	12' 2"	13' 11"	12' 2"	10' 8"	12' 1"	11' 1"	9' 8"
550SFS-33EQD <sup>1</sup>	57	12	28' 5"	22' 8"	19' 10"	23' 3"	19' 10"	17' 4"	20' 1"	18' 0"	15' 9"
	57	16	24' 8"	20' 7"	18' 0"	20' 1"	18' 0"	15' 9"	17' 5"	16' 4"	14' 3"
	57	24	20' 1"	18' 0"	15' 9"	16' 5" e	15' 9" e	13' 9"	14' 2"	14' 2"	12' 6"
600SFS-33EQD <sup>1</sup>	57	12	29' 8"	23' 7"	20' 8"	24' 2"	20' 8"	18' 0"	20' 11"	18' 9"	16' 4"
	57	16	25' 8"	21' 5"	18' 9"	20' 11"	18' 9"	16' 4"	18' 2"	17' 0"	14' 10"
	57	24	20' 11"	18' 9"	16' 4"	17' 1"	16' 4"	14' 3"	14' 10"	14' 10"	13' 0"

<sup>1</sup> Web height-to-thickness ratio exceeds 200. Web stiffeners are required at all support points and concentrated loads.  
 "e" Web stiffeners required at ends.

See Table Notes on page 13



## Table Notes

1. Heights based on steel properties only.
2. Limiting heights based on lateral and torsional bracing spaced 48" on center, full height of member.
3. Deflection and Strength Calculations based on a 1.0 factor.
4. Allowable moment is the lesser of  $M_{sl}$  and  $M_{sd}$ . Stud distortional buckling based on an assumed  $K\phi = 0$ .

Non-Composite - Braced at 48" On Center											
Part No.	F <sub>y</sub> (ksi)	Spacing (in) oc	5 psf			7.5 psf			10 psf		
			L/120	L/240	L/360	L/120	L/240	L/360	L/120	L/240	L/360
162SFS125-D25	57	12	-	-	-	-	-	-	-	-	-
	57	16	-	-	-	-	-	-	-	-	-
	57	24	-	-	-	-	-	-	-	-	-
250SFS125-D25	57	12	10' 11"	10' 5"	9' 1"	8' 11"	8' 11"	-	-	-	-
	57	16	9' 6"	9' 5"	8' 3"	-	-	-	-	-	-
	57	24	-	-	-	-	-	-	-	-	-
350SFS125-D25	57	12	12' 10"	12' 10"	11' 8"	10' 5"	10' 5"	10' 2"	9' 1"	9' 1"	9' 1"
	57	16	11' 1"	11' 1"	10' 7"	9' 1"	9' 1"	9' 1"	-	-	-
	57	24	9' 1"	9' 1"	9' 1"	-	-	-	-	-	-
362SFS125-D25	57	12	13' 1"	13' 1"	12' - 0"	10' 8"	10' 8"	10' 5"	9' 3"	9' 3"	9' 3"
	57	16	11' 4"	11' 4"	10' 10"	9' 3"	9' 3"	9' 3"	8' 0"	8' 0"	8' 0"
	57	24	9' 3"	9' 3"	9' 3"	-	-	-	-	-	-
400SFS125-D25	57	12	14' - 0"	14' - 0"	12' 10"	11' 5"	11' 5"	11' 3"	9' 11"	9' 11"	9' 11"
	57	16	12' 1"	12' 1"	11' 8"	9' 11"	9' 11"	9' 11"	8' 3"	8' 3"	8' 3"
	57	24	9' 11"	9' 11"	9' 11"	-	-	-	-	-	-
162SFS-D20	57	12	10' 2"	8' 2"	-	8' 3"	-	-	-	-	-
	57	16	8' 9"	-	-	-	-	-	-	-	-
	57	24	-	-	-	-	-	-	-	-	-
250SFS-D20	57	12	13' 5"	11' 3"	9' 10"	11' 0"	9' 10"	8' 7"	9' 6"	8' 11"	-
	57	16	11' 8"	10' 3"	8' 11"	9' 6"	8' 11"	-	8' 3"	8' 2"	-
	57	24	9' 6"	8' 11"	-	-	-	-	-	-	-
350SFS-D20	57	12	16' 6"	14' 6"	12' 8"	13' 5"	12' 8"	11' 1"	11' 8"	11' 6"	10' 1"
	57	16	14' 3"	13' 2"	11' 6"	11' 8"	11' 6"	10' 1"	10' 1"	10' 1"	9' 2"
	57	24	11' 8"	11' 6"	10' 1"	9' 6"	9' 6"	8' 9"	8' 3"	8' 3"	8' 0"
362SFS-D20	57	12	16' 9"	14' 11"	13' 0"	13' 8"	13' 0"	11' 5"	11' 10"	11' 10"	10' 4"
	57	16	14' 6"	13' 7"	11' 10"	11' 10"	11' 10"	10' 4"	10' 3"	10' 3"	9' 5"
	57	24	11' 10"	11' 10"	10' 4"	9' 8"	9' 8"	9' 0"	8' 5"	8' 5"	8' 2"
400SFS-D20	57	12	17' 5"	15' 9"	13' 9"	14' 3"	13' 9"	12' 1"	12' 4"	12' 4"	10' 11"
	57	16	15' 1"	14' 4"	12' 6"	12' 4"	12' 4"	10' 11"	10' 8"	10' 8"	9' 11"
	57	24	12' 4"	12' 4"	10' 11"	10' 1"	10' 1"	9' 7"	8' 9"	8' 9"	8' 8"
162SFS-30EQD	57	12	11' 0"	8' 9"	-	9' 8"	-	-	8' 9"	-	-
	57	16	10' 0"	-	-	8' 9"	-	-	-	-	-
	57	24	8' 9"	-	-	-	-	-	-	-	-
250SFS-30EQD	57	12	15' 4"	12' 2"	10' 7"	13' 5"	10' 7"	9' 3"	12' 2"	9' 8"	8' 5"
	57	16	13' 11"	11' 1"	9' 8"	12' 2"	9' 8"	8' 5"	11' 1"	8' 9"	-
	57	24	12' 2"	9' 8"	8' 5"	10' 7"	8' 5"	-	9' 2"	-	-
350SFS-30EQD	57	12	19' 11"	15' 10"	13' 10"	17' 0"	13' 10"	12' 1"	14' 9"	12' 7"	10' 11"
	57	16	18' 0"	14' 4"	12' 7"	14' 8"	12' 7"	10' 11"	12' 8"	11' 5"	9' 11"
	57	24	14' 8"	12' 7"	10' 11"	12' 0"	10' 11"	9' 7"	10' 4"	9' 11"	8' 8"
362SFS-30EQD	57	12	20' 6"	16' 3"	14' 2"	17' 4"	14' 2"	12' 5"	15' 0"	12' 11"	11' 3"
	57	16	18' 4"	14' 9"	12' 11"	14' 11"	12' 11"	11' 3"	12' 11"	11' 9"	10' 3"
	57	24	14' 11"	12' 11"	11' 3"	12' 2"	11' 3"	9' 10"	10' 7"	10' 3"	8' 11"
400SFS-30EQD	57	12	22' 2"	17' 7"	15' 4"	18' 3"	15' 4"	13' 5"	15' 9"	13' 11"	12' 2"
	57	16	19' 3"	16' 0"	13' 11"	15' 9"	13' 11"	12' 2"	13' 7"	12' 8"	11' 1"
	57	24	15' 9"	13' 11"	12' 2"	12' 10"	12' 2"	10' 8"	11' 1"	11' 1"	9' 8"
550SFS-30EQD <sup>1</sup>	57	12	28' 2"	22' 8"	19' 10"	23' 7"	23' 0"	19' 10"	17' 4"	19' 11"	15' 9"
	57	16	24' 3"	20' 7"	18' 0"	20' 4"	19' 10"	18' 0"	15' 9" e	17' 2"	14' 3"
	57	24	19' 10"	18' 0"	16' 4"	15' 9"	16' 2"	15' 9"	13' 9" e	14' 0"	12' 6"
600SFS-30EQD <sup>1</sup>	57	12	28' 11"	23' 7"	20' 8"	23' 7"	20' 8"	18' 0"	20' 5"	18' 9"	16' 4"
	57	16	24' 11"	21' 5"	18' 9"	20' 4"	18' 9"	16' 4"	17' 8"	17' 0"	14' 10"
	57	24	20' 4"	18' 9"	16' 4"	16' 8"	16' 4"	14' 3"	14' 5"	14' 5"	13' 0"

<sup>1</sup> Web height-to-thickness ratio exceeds 200. Web stiffeners are required at all support points and concentrated loads.  
"e" Web stiffeners required at ends.

# Non-Composite Interior Wall Heights

## Non-Composite - Braced at 48" On Center

Part No.	F <sub>y</sub> (ksi)	Spacing (in) oc	5 psf			7.5 psf			10 psf		
			L/120	L/240	L/360	L/120	L/240	L/360	L/120	L/240	L/360
162SFS-33EQD	57	12	11' 0"	8' 9"	-	9' 8"	-	-	8' 9"	-	-
	57	16	10' 0"	-	-	8' 9"	-	-	-	-	-
	57	24	8' 9"	-	-	-	-	-	-	-	-
250SFS-33EQD	57	12	15' 4"	12' 2"	10' 7"	13' 5"	10' 7"	9' 3"	12' 2"	9' 8"	8' 5"
	57	16	13' 11"	11' 1"	9' 8"	12' 2"	9' 8"	8' 5"	11' 1"	8' 9"	-
	57	24	12' 2"	9' 8"	8' 5"	10' 7"	8' 5"	-	9' 2"	-	-
350SFS-33EQD	57	12	19' 11"	15' 10"	13' 10"	17' 0"	13' 10"	12' 1"	14' 9"	12' 7"	10' 11"
	57	16	18' 0"	14' 4"	12' 7"	14' 8"	12' 7"	10' 11"	12' 8"	11' 5"	9' 11"
	57	24	14' 8"	12' 7"	10' 11"	12' 0"	10' 11"	9' 7"	10' 4"	9' 11"	8' 8"
362SFS-33EQD	57	12	20' 6"	16' 3"	14' 2"	17' 4"	14' 2"	12' 5"	15' 0"	12' 11"	11' 3"
	57	16	18' 4"	14' 9"	12' 11"	14' 11"	12' 11"	11' 3"	12' 11"	11' 9"	10' 3"
	57	24	14' 11"	12' 11"	11' 3"	12' 2"	11' 3"	9' 10"	10' 7"	10' 3"	8' 11"
400SFS-33EQD	57	12	22' 2"	17' 7"	15' 4"	18' 3"	15' 4"	13' 5"	15' 9"	13' 11"	12' 2"
	57	16	19' 3"	16' 0"	13' 11"	15' 9"	13' 11"	12' 2"	13' 7"	12' 8"	11' 1"
	57	24	15' 9"	13' 11"	12' 2"	12' 10"	12' 2"	10' 8"	11' 1"	11' 1"	9' 8"
550SFS-33EQD <sup>1</sup>	57	12	28' 2"	22' 8"	19' 10"	23' 7"	23' 0"	19' 10"	17' 4"	19' 11"	15' 9"
	57	16	24' 3"	20' 7"	18' 0"	20' 4"	19' 10"	18' 0"	15' 9"	17' 2"	14' 3"
	57	24	19' 10"	18' 0"	16' 4"	15' 9"	16' 2"	15' 9"	13' 9"	14' 0"	12' 6"
600SFS-33EQD <sup>1</sup>	57	12	28' 11"	23' 7"	20' 8"	23' 7"	20' 8"	18' 0"	20' 5"	18' 9"	16' 4"
	57	16	24' 11"	21' 5"	18' 9"	20' 4"	18' 9"	16' 4"	17' 8"	17' 0"	14' 10"
	57	24	20' 4"	18' 9"	16' 4"	16' 8"	16' 4"	14' 3"	14' 5"	14' 5"	13' 0"

<sup>1</sup>Web height-to-thickness ratio exceeds 200. Web stiffeners are required at all support points and concentrated loads.  
<sup>2</sup>"e" Web stiffeners required at ends.

See Table Notes on page 15.



## Lateral Bracing

Example of lateral bracing at wall not sheathed at full height.

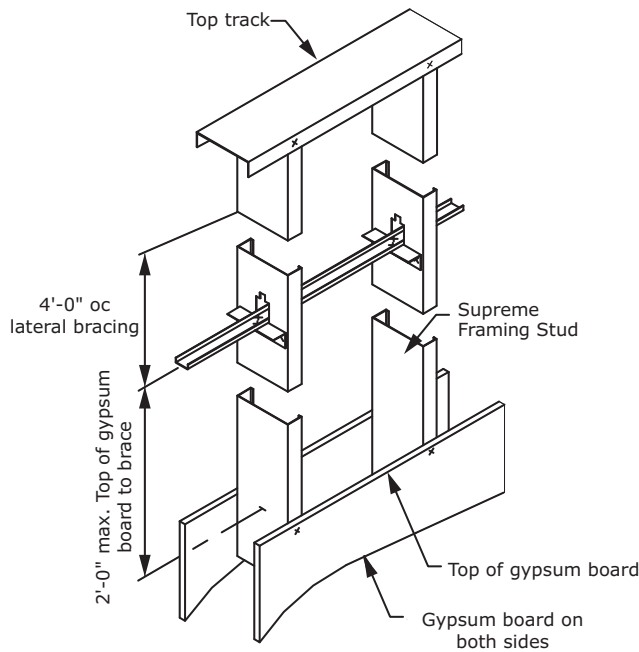

## Lateral Bracing

Example of lateral bracing at wall sheathed at full height on one side.

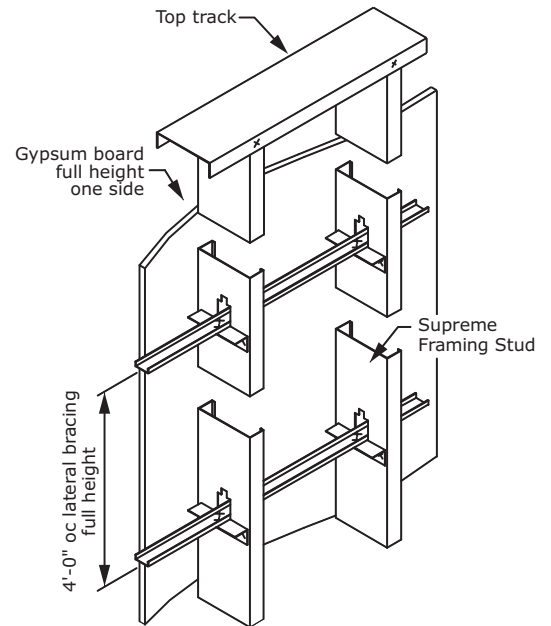

## Flat Strap Lateral Bracing

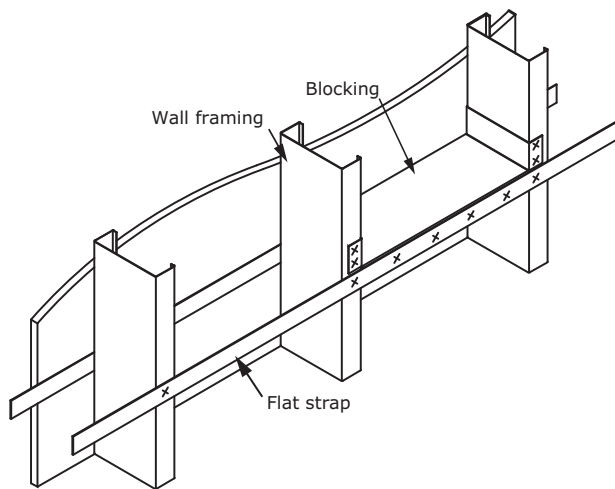

## Deflection Track

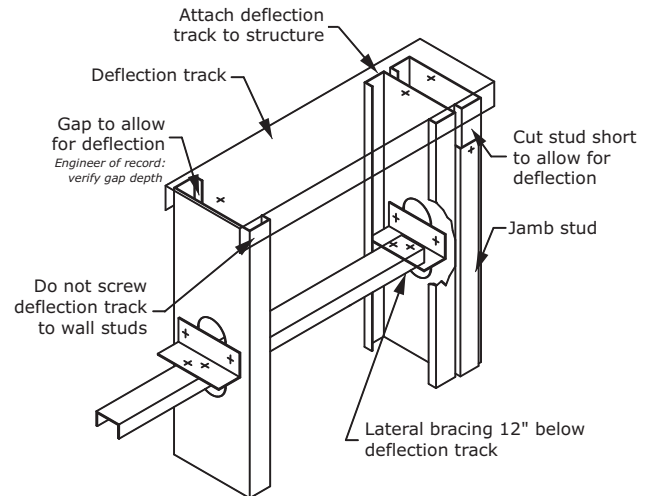

## U-Channel Lateral Bracing

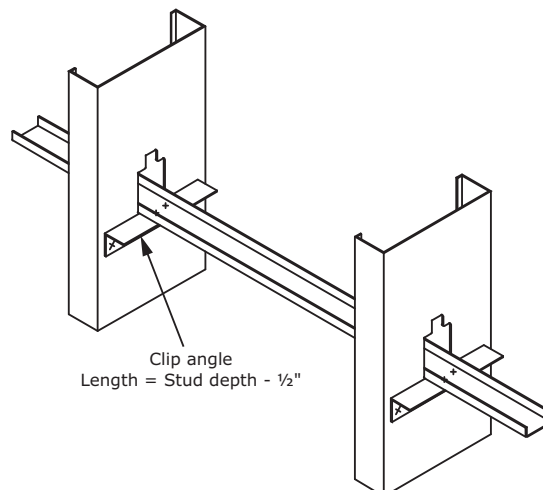

**General Note:**  
All connections should be designed by a licensed design professional.

# Curtain Wall Limiting Heights

## Table Notes

1. Listed wind pressures represent calculated designed wind pressure (1.0 W based on 2009 IBC or 0.6 W based on 2012 IBC). For deflection calculations, listed wind pressures have been reduced by 0.70 as allowed by IBC. The 5 psf pressure has not been reduced for deflection checks.
2. Studs must be braced against rotation and lateral movement at all supports. See typical bracing details on page 17.
3. Studs are assumed to be adequately braced at a maximum spacing of  $L_u$  to develop full allowable moment.
4. Web crippling check is based on 1" of bearing at end supports and 3" of bearing at interior support.
5. Shear and web crippling capacity at end supports have **not** been reduced for punchouts. Shear and web crippling capacity at interior support have been reduced for the presence of punchout adjacent to the support.
6. Combined bending and shear check at interior support is based on unreinforced web per AISI S100 (Eq. C3.3.1-1). Shear capacity and combined bending and shear check at interior support have been reduced for the presence of punchouts adjacent to support.
7. See page 5 for additional table notes.

350 SFS														
Part No.	F <sub>y</sub> (ksi)	Spacing (in) oc	5 psf			15 psf			20 psf			25 psf		
			L/120	L/240	L/360	L/240	L/360	L/600	L/240	L/360	L/600	L/240	L/360	L/600
350SFS162-33EQS	57	12	22' 4"	17' 8"	15' 5"	13' 10"	12' 1"	10' 2"	12' 6"	10' 11"	9' 3"	11' 8"	10' 2"	8' 7"
	57	16	20' 3"	16' 1"	14' 0"	12' 6"	10' 11"	9' 3"	11' 5"	9' 11"	8' 5"	10' 7"	9' 3"	-
	57	24	17' 8"	14' 0"	12' 3"	10' 11"	9' 7"	8' 1"	9' 11"	8' 8"	-	8' 11" e	8' 1"	-
350SFS162-43EQS	57	12	24' 10"	19' 8"	17' 2"	15' 4"	13' 5"	11' 4"	13' 11"	12' 2"	10' 3"	12' 11"	11' 4"	9' 6"
	57	16	22' 6"	17' 10"	15' 7"	13' 11"	12' 2"	10' 3"	12' 8"	11' 1"	9' 4"	11' 9"	10' 3"	8' 8"
	57	24	19' 8"	15' 7"	13' 8"	12' 2"	10' 8"	9' 0"	11' 1"	9' 8"	8' 2"	10' 3"	9' 0"	-
350SFS200-43EQS	57	12	25' 9"	20' 5"	17' 10"	16' 2"	14' 1"	11' 11"	14' 8"	12' 10"	10' 10"	13' 7"	11' 11"	10' 0"
	57	16	23' 4"	18' 6"	16' 2"	14' 8"	12' 10"	10' 10"	13' 4"	11' 8"	9' 10"	12' 4"	10' 10"	9' 1"
	57	24	20' 4"	16' 2"	14' 2"	12' 10"	11' 2"	9' 5"	11' 8"	10' 2"	8' 7"	10' 10"	9' 5"	8' 0"

Part No.	F <sub>y</sub> (ksi)	Spacing (in) oc	30 psf			35 psf			40 psf			50 psf		
			L/240	L/360	L/600	L/240	L/360	L/600	L/240	L/360	L/600	L/240	L/360	L/600
350SFS162-33EQS	57	12	10' 11"	9' 7"	8' 1"	10' 5"	9' 1"	-	9' 11"	8' 8"	-	8' 11" e	8' 1"	-
	57	16	9' 11"	8' 8"	-	9' 3" e	8' 3"	-	8' 8" e	-	-	-	-	-
	57	24	8' 2" e	-	-	-	-	-	-	-	-	-	-	-
350SFS162-43EQS	57	12	12' 2"	10' 8"	9' 0"	11' 7"	10' 1"	8' 6"	11' 1"	9' 8"	8' 2"	10' 3"	9' 0"	-
	57	16	11' 1"	9' 8"	8' 2"	10' 6"	9' 2"	-	10' 1"	8' 9"	-	9' 4"	8' 2"	-
	57	24	9' 8"	8' 5"	-	9' 1"	8' 0"	-	8' 6"	-	-	-	-	-
350SFS200-43EQS	57	12	12' 10"	11' 2"	9' 5"	12' 2"	10' 8"	9' 0"	11' 8"	10' 2"	8' 7"	10' 10"	9' 5"	8' 0"
	57	16	11' 8"	10' 2"	8' 7"	11' 1"	9' 8"	8' 2"	10' 7"	9' 3"	-	9' 6"	8' 7"	-
	57	24	10' 1"	8' 11"	-	9' 4"	8' 5"	-	8' 9"	8' 1"	-	-	-	-

"e" Web stiffeners required at ends.

362 SFS														
Part No.	Fy (ksi)	Spacing (in) oc	5 psf			15 psf			20 psf			25 psf		
			L/120	L/240	L/360	L/240	L/360	L/600	L/240	L/360	L/600	L/240	L/360	L/600
362SFS162-33EQS	57	12	22' 11"	18' 2"	15' 11"	14' 2"	12' 5"	10' 5"	12' 11"	11' 3"	9' 6"	12' 0"	10' 5"	8' 10"
	57	16	20' 10"	16' 6"	14' 5"	12' 11"	11' 3"	9' 6"	11' 8"	10' 3"	8' 7"	10' 10"	9' 6"	8' 0"
	57	24	18' 2"	14' 5"	12' 7"	11' 3"	9' 10"	8' 3"	10' 2"	8' 11"	-	9' 1" e	8' 3"	-
362SFS162-43EQS	57	12	25' 6"	20' 3"	17' 8"	15' 9"	13' 9"	11' 7"	14' 4"	12' 6"	10' 7"	13' 4"	11' 7"	9' 9"
	57	16	23' 2"	18' 4"	16' 0"	14' 4"	12' 6"	10' 7"	13' 0"	11' 4"	9' 7"	12' 1"	10' 7"	8' 11"
	57	24	20' 3"	16' 0"	14' 0"	12' 6"	10' 11"	9' 2"	11' 4"	9' 11"	8' 4"	10' 7"	9' 2"	7' 9"
362SFS200-43EQS	57	12	26' 5"	21' 0"	18' 4"	16' 7"	14' 6"	12' 3"	15' 1"	13' 2"	11' 1"	14' 0"	12' 3"	10' 4"
	57	16	24' 0"	19' 1"	16' 8"	15' 1"	13' 2"	11' 1"	13' 8"	11' 11"	10' 1"	12' 8"	11' 1"	9' 4"
	57	24	21' 0"	16' 8"	14' 6"	13' 2"	11' 6"	9' 8"	11' 11"	10' 5"	8' 10"	11' 1"	9' 8"	8' 2"

Part No.	Fy (ksi)	Spacing (in) oc	30 psf			35 psf			40 psf			50 psf		
			L/240	L/360	L/600	L/240	L/360	L/600	L/240	L/360	L/600	L/240	L/360	L/600
362SFS162-33EQS	57	12	11' 3"	9' 10"	8' 3"	10' 8"	9' 4"	-	10' 2"	8' 11"	-	9' 1" e	8' 3"	-
	57	16	10' 2"	8' 11"	-	9' 5" e	8' 6"	-	8' 10" e	8' 1" e	-	-	-	-
	57	24	8' 3" e	-	-	-	-	-	-	-	-	-	-	-
362SFS162-43EQS	57	12	12' 6"	10' 11"	9' 2"	11' 11"	10' 5"	8' 9"	11' 4"	9' 11"	8' 4"	10' 7"	9' 2"	7' 9"
	57	16	11' 4"	9' 11"	8' 4"	10' 10"	9' 5"	7' 11"	10' 4"	9' 0"	7' 7"	9' 6"	8' 4"	7' 1"
	57	24	9' 11"	8' 8"	7' 4"	9' 3"	8' 3"	6' 11"	8' 8"	7' 10"	6' 8"	7' 9"	7' 4"	6' 2"
362SFS200-43EQS	57	12	13' 2"	11' 6"	9' 8"	12' 6"	10' 11"	9' 3"	11' 11"	10' 5"	8' 10"	11' 1"	9' 8"	8' 2"
	57	16	11' 11"	10' 5"	8' 10"	11' 4"	9' 11"	8' 4"	10' 10"	9' 6"	8' 0"	9' 9"	8' 10"	-
	57	24	10' 3"	9' 2"	-	9' 6"	8' 8"	-	8' 11"	8' 3"	-	-	-	-

"e" Web stiffeners required at ends.

400 SFS														
Part No.	Fy (ksi)	Spacing (in) oc	5 psf			15 psf			20 psf			25 psf		
			L/120	L/240	L/360	L/240	L/360	L/600	L/240	L/360	L/600	L/240	L/360	L/600
400SFS162-33EQS	57	12	24' 9"	19' 8"	17' 2"	15' 4"	13' 5"	11' 3"	13' 11"	12' 2"	10' 3"	12' 11"	11' 3"	9' 6"
	57	16	22' 6"	17' 10"	15' 7"	13' 11"	12' 2"	10' 3"	12' 8"	11' 0"	9' 4"	11' 9"	10' 3"	8' 8"
	57	24	19' 8"	15' 7"	13' 7"	12' 2"	10' 7"	8' 11"	10' 9" e	9' 8"	8' 1"	9' 7" e	8' 11" e	-
400SFS162-43EQS	57	12	27' 6"	21' 10"	19' 1"	17' 0"	14' 10"	12' 6"	15' 6"	13' 6"	11' 5"	14' 4"	12' 6"	10' 7"
	57	16	25' 0"	19' 10"	17' 4"	15' 6"	13' 6"	11' 5"	14' 1"	12' 3"	10' 4"	13' 0"	11' 5"	9' 7"
	57	24	21' 10"	17' 4"	15' 1"	13' 6"	11' 9"	9' 11"	12' 3"	10' 9"	9' 0"	11' 5"	9' 11"	8' 5"
400SFS200-43EQS	57	12	28' 6"	22' 7"	19' 9"	17' 10"	15' 7"	13' 2"	16' 3"	14' 2"	12' 0"	15' 1"	13' 2"	11' 1"
	57	16	25' 11"	20' 7"	17' 11"	16' 3"	14' 2"	12' 0"	14' 9"	12' 11"	10' 10"	13' 8"	12' 0"	10' 1"
	57	24	22' 7"	17' 11"	15' 8"	14' 2"	12' 5"	10' 5"	12' 11"	11' 3"	9' 6"	11' 10"	10' 5"	8' 10"

Part No.	Fy (ksi)	Spacing (in) oc	30 psf			35 psf			40 psf			50 psf		
			L/240	L/360	L/600	L/240	L/360	L/600	L/240	L/360	L/600	L/240	L/360	L/600
400SFS162-33EQS	57	12	12' 2"	10' 7"	8' 11"	11' 6"	10' 1"	8' 6"	10' 9" e	9' 8"	8' 1"	9' 7" e	8' 11" e	-
	57	16	10' 9" e	9' 8"	8' 1"	9' 11" e	9' 2" e	-	9' 3" e	8' 9" e	-	8' 4" e	8' 1" e	-
	57	24	8' 9" e	8' 5" e	-	8' 1" e	8' 0" e	-	-	-	-	-	-	-
400SFS162-43EQS	57	12	13' 6"	11' 9"	9' 11"	12' 10"	11' 2"	9' 5"	12' 3"	10' 9"	9' 0"	11' 5"	9' 11"	8' 5"
	57	16	12' 3"	10' 9"	9' 0"	11' 8"	10' 2"	8' 7"	11' 2"	9' 9"	8' 2"	10' 1"	9' 0"	7' 7"
	57	24	10' 7"	9' 4"	7' 11"	9' 10"	8' 11"	7' 6"	9' 2"	8' 6"	7' 2"	8' 2" e	7' 11" e	6' 8"
400SFS200-43EQS	57	12	14' 2"	12' 5"	10' 5"	13' 6"	11' 9"	9' 11"	12' 11"	11' 3"	9' 6"	11' 10"	10' 5"	8' 10"
	57	16	12' 11"	11' 3"	9' 6"	12' 3"	10' 8"	9' 0"	11' 6"	10' 3"	8' 8"	10' 3"	9' 6"	8' 0"
	57	24	10' 10"	9' 10"	8' 4"	10' 0"	9' 4"	-	9' 4"	8' 11"	-	8' 5" e	8' 4" e	-

"e" Web stiffeners required at ends.

# Curtain Wall Limiting Heights

550 SFS														
Part No.	F <sub>y</sub> (ksi)	Spacing (in) oc	5 psf			15 psf			20 psf			25 psf		
			L/120	L/240	L/360	L/240	L/360	L/600	L/240	L/360	L/600	L/240	L/360	L/600
550SFS162-33EQS	57	12	31' 10"	25' 3"	22' 1"	19' 9"	17' 3"	14' 6"	17' 11"	15' 8"	13' 2"	16' 1" e	14' 6"	12' 3"
	57	16	28' 11"	22' 11"	20' 0"	17' 11"	15' 8"	13' 2"	15' 7" e	14' 2"	12' 0"	13' 11" e	13' 2" e	11' 1"
	57	24	25' 3"	20' 0"	17' 6"	14' 8" e	13' 8" e	11' 6"	12' 8" e	12' 5" e	10' 5" e	11' 4" e	11' 4" e	9' 8" e
550SFS162-43EQS	57	12	35' 3"	28' 0"	24' 5"	21' 10"	19' 1"	16' 1"	19' 10"	17' 4"	14' 7"	18' 5"	16' 1"	13' 7"
	57	16	32' 0"	25' 5"	22' 2"	19' 10"	17' 4"	14' 7"	18' 0"	15' 9"	13' 3"	16' 9"	14' 7"	12' 4"
	57	24	28' 0"	22' 2"	19' 5"	17' 4"	15' 2"	12' 9"	15' 9"	13' 9"	11' 7"	14' 1"	12' 9"	10' 9"
550SFS200-43EQS	57	12	26' 6"	29' 0"	25' 4"	22' 10"	19' 11"	16' 10"	20' 9"	18' 1"	15' 3"	19' 3"	16' 10"	14' 2"
	57	16	33' 2"	26' 4"	23' 0"	20' 9"	18' 1"	15' 3"	18' 10"	16' 5"	13' 11"	17' 6"	15' 3"	12' 11"
	57	24	29' 0"	23' 0"	20' 1"	18' 1"	15' 10"	13' 4"	16' 1"	14' 4"	12' 1"	14' 5" e	13' 4"	11' 3"

Part No.	F <sub>y</sub> (ksi)	Spacing (in) oc	30 psf			35 psf			40 psf			50 psf		
			L/240	L/360	L/600	L/240	L/360	L/600	L/240	L/360	L/600	L/240	L/360	L/600
550SFS162-33EQS	57	12	14' 8" e	13' 8" e	11' 6"	13' 7" e	13' 0" e	10' 11"	12' 8" e	12' 5" e	10' 5" e	11' 4" e	11' 4" e	9' 8" e
	57	16	12' 8" e	12' 5" e	10' 5" e	11' 9" e	11' 9" e	9' 11" e	11' 0" e	11' 0" e	9' 6" e	9' 10" e	9' 10" e	8' 10" e
	57	24	10' 4" e	10' 4" e	9' 2" e	9' 7" e	9' 7" e	8' 8" e	9' 0" e	9' 0" e	8' 3" e	8' 0" e	8' 0" e	-
550SFS162-43EQS	57	12	17' 4"	15' 2"	12' 9"	16' 6"	14' 4"	12' 1"	15' 9"	13' 9"	11' 7"	14' 1"	12' 9"	10' 9"
	57	16	15' 9"	13' 9"	11' 7"	14' 7"	13' 1"	11' 0"	13' 8" e	12' 6"	10' 6"	12' 2" e	11' 7" e	9' 9"
	57	24	12' 10" e	12' 0" e	10' 1"	11' 11" e	11' 5" e	9' 7"	11' 1" e	10' 11" e	9' 2" e	9' 11" e	9' 11" e	8' 6" e
550SFS200-43EQS	57	12	18' 1"	15' 10"	13' 4"	17' 2"	15' 0"	12' 8"	16' 1"	14' 4"	12' 1"	14' 5" e	13' 4"	11' 3"
	57	16	16' 1"	14' 4"	12' 1"	14' 11"	13' 8"	11' 6"	13' 11" e	13' 1"	11' 0"	12' 6" e	12' 1" e	10' 3"
	57	24	13' 2" e	12' 7" e	10' 7"	12' 2" e	11' 11" e	10' 1"	11' 4" e	11' 4" e	9' 7" e	10' 2" e	10' 2" e	8' 11" e

600 SFS														
Part No.	F <sub>y</sub> (ksi)	Spacing (in) oc	5 psf			15 psf			20 psf			25 psf		
			L/120	L/240	L/360	L/240	L/360	L/600	L/240	L/360	L/600	L/240	L/360	L/600
600SFS162-33EQS	57	12	34' 2"	27' 1"	23' 8"	21' 2"	18' 6"	15' 7"	18' 9"	16' 9"	14' 2"	16' 9" e	15' 7" e	13' 1"
	57	16	31' 0"	24' 7"	21' 6"	18' 9"	16' 9"	14' 2"	16' 3" e	15' 3" e	12' 10"	14' 6" e	14' 2" e	11' 11" e
	57	24	26' 7"	21' 6"	18' 9"	15' 4" e	14' 8" e	12' 4"	13' 3" e	13' 3" e	11' 3" e	11' 10" e	11' 10" e	10' 5" e
600SFS162-43EQS	57	12	37' 9"	30' 0"	26' 2"	23' 5"	20' 5"	17' 3"	21' 3"	18' 7"	15' 8"	19' 9"	17' 3"	14' 6"
	57	16	34' 4"	27' 3"	23' 9"	21' 3"	18' 7"	15' 8"	19' 4"	16' 10"	14' 3"	17' 11"	15' 8"	13' 2"
	57	24	30' 0"	23' 9"	20' 9"	18' 7"	16' 3"	13' 8"	16' 6"	14' 9"	12' 5"	14' 9" e	13' 8"	11' 6"
600SFS200-43EQS	57	12	39' 2"	31' 1"	27' 2"	24' 5"	21' 4"	18' 0"	22' 2"	19' 5"	16' 4"	20' 7"	18' 0"	15' 2"
	57	16	35' 7"	28' 3"	24' 8"	22' 2"	19' 5"	16' 4"	20' 2"	17' 7"	14' 10"	18' 5"	16' 4"	13' 9"
	57	24	31' 1"	24' 8"	21' 7"	19' 5"	16' 11"	14' 3"	16' 10"	15' 5"	13' 0"	15' 1" e	14' 3" e	12' 1"

Part No.	F <sub>y</sub> (ksi)	Spacing (in) oc	30 psf			35 psf			40 psf			50 psf		
			L/240	L/360	L/600	L/240	L/360	L/600	L/240	L/360	L/600	L/240	L/360	L/600
600SFS162-33EQS	57	12	15' 4" e	14' 8" e	12' 4"	14' 2" e	13' 11" e	11' 9" e	13' 3" e	13' 3" e	11' 3" e	11' 10" e	11' 10" e	10' 5" e
	57	16	13' 3" e	13' 3" e	11' 3" e	12' 3" e	12' 3" e	10' 8" e	11' 6" e	11' 6" e	10' 2" e	10' 3" e	10' 3" e	9' 5" e
	57	24	10' 10" e	10' 10" e	9' 9" e	10' 0" e	10' 0" e	9' 4" e	9' 4" e	9' 4" e	8' 11" e	-	-	-
600SFS162-43EQS	57	12	18' 7"	16' 3"	13' 8"	17' 7"	15' 5"	13' 0"	16' 6"	14' 9"	12' 5"	14' 9" e	13' 8"	11' 6"
	57	16	16' 6"	14' 9"	12' 5"	15' 3" e	14' 0"	11' 10"	14' 3" e	13' 5" e	11' 3"	12' 9" e	12' 5" e	10' 6"
	57	24	13' 5" e	12' 10" e	10' 10"	12' 5" e	12' 3" e	10' 4" e	11' 8" e	11' 8" e	9' 10" e	10' 5" e	10' 5" e	9' 2" e
600SFS200-43EQS	57	12	19' 5"	16' 11"	14' 3"	18' 0"	16' 1"	13' 7"	16' 10"	15' 5"	13' 0"	15' 1" e	14' 3" e	12' 1"
	57	16	16' 10"	15' 5"	13' 0"	15' 7" e	14' 7"	12' 4"	14' 7" e	14' 0" e	11' 9"	13' 1" e	13' 0" e	10' 11" e
	57	24	13' 9" e	13' 5" e	11' 4"	12' 9" e	12' 9" e	10' 9" e	11' 11" e	11' 11" e	10' 4" e	10' 8" e	10' 8" e	9' 7" e

"e" Web stiffeners required at ends.

See Table Notes on page 18

800 SFS														
Part No.	Fy (ksi)	Spacing (in) oc	5 psf			15 psf			20 psf			25 psf		
			L/120	L/240	L/360	L/240	L/360	L/600	L/240	L/360	L/600	L/240	L/360	L/600
800SFS162-43EQS	57	12	46' 9"	37' 1"	32' 5"	28' 11"	25' 3"	21' 4"	26' 3"	23' 0"	19' 4"	24' 0"	21' 4"	18' 0"
	57	16	42' 5"	33' 8"	29' 5"	26' 3"	23' 0"	19' 4"	23' 3"	20' 10"	17' 7"	20' 9" e	19' 4"	16' 4"
	57	24	37' 1"	29' 5"	25' 8"	21' 11"	20' 1"	16' 11"	19' 0" e	18' 3" e	15' 4"	16' 11" e	16' 11" e	14' 3" e
800SFS200-43EQS	57	12	49' 5"	39' 2"	34' 3"	30' 8"	26' 9"	22' 7"	27' 6"	24' 4"	20' 6"	24' 7"	22' 7"	19' 0"
	57	16	44' 10"	35' 7"	31' 1"	27' 6"	24' 4"	20' 6"	23' 10"	22' 1"	18' 8"	21' 4" e	20' 6" e	17' 4"
	57	24	38' 11"	31' 1"	27' 2"	22' 6" e	21' 3"	17' 11"	19' 6" e	19' 4" e	16' 3"	17' 5" e	17' 5" e	15' 1" e

Part No.	Fy (ksi)	Spacing (in) oc	30 psf			35 psf			40 psf			50 psf		
			L/240	L/360	L/600	L/240	L/360	L/600	L/240	L/360	L/600	L/240	L/360	L/600
800SFS162-43EQS	57	12	21' 11"	20' 1"	16' 11"	20' 3" e	19' 1"	16' 1"	19' 0" e	18' 3" e	15' 4"	16' 11" e	16' 11" e	14' 3" e
	57	16	19' 0" e	18' 3" e	15' 4"	17' 7" e	17' 4" e	14' 7" e	16' 5" e	16' 5" e	13' 11" e	14' 8" e	14' 8" e	12' 11" e
	57	24	15' 6" e	15' 6" e	13' 5" e	14' 4" e	14' 4" e	12' 9" e	13' 5" e	13' 5" e	12' 2" e	12' 0" e	12' 0" e	11' 4" e
800SFS200-43EQS	57	12	22' 6" e	21' 3"	17' 11"	20' 10" e	20' 2" e	17' 0"	19' 6" e	19' 4" e	16' 3"	17' 5" e	17' 5" e	15' 1" e
	57	16	19' 6" e	19' 4" e	16' 3"	18' 0" e	18' 0" e	15' 6" e	16' 10" e	16' 10" e	14' 9" e	15' 1" e	15' 1" e	13' 9" e
	57	24	15' 11" e	15' 11" e	14' 3" e	14' 9" e	14' 9" e	13' 6" e	13' 9" e	13' 9" e	12' 11" e	12' 4" e	12' 4" e	12' 0" e

"e" Web stiffeners required at ends.

See Table Notes on page 18

# Combined Axial and Lateral Loads

## Table Notes

1. Allowable axial loads listed in kips (1 kip = 1000 pounds).
2. Allowable axial loads listed are based on simple single span condition.
3. Allowable axial load determined in accordance with AISI S100 Section C5 and with the assumption that axial load passes through centroid of the effective section.
4. Allowable axial loads are based on 4'-0" on center bracing.
5. Studs are assumed to be adequately braced at a maximum of spacing of  $L_u$  to develop full allowable moment,  $M_u$ .
6. Listed wind pressures represent calculated designed wind pressure (1.0 W based on 2009 IBC or 0.6 W based on 2012 IBC). For deflection calculations, listed wind pressures have been reduced by 0.70 as allowed by IBC. The 5 psf pressure has not been reduced for deflection checks.
7. Ends supports have not been checked for web crippling. See web crippling tables on page 28.
8. See page 5 for additional table notes.

		5 psf									
Wall Height (ft)	Spacing (in) on center	362SFS162-(mil)		400SFS162-(mil)		600SFS162-(mil)		600SFS200-(mil)	800SFS162-(mil)	800SFS200-(mil)	
		57 ksi		57 ksi		57 ksi		57 ksi	57 ksi	57 ksi	
		33EQS	43EQS	33EQS	43EQS	33EQS	43EQS	43EQS	43EQS	43EQS	
8	12	1.79	2.74	1.98	3.07	2.43	3.85	4.14	3.71	4.29	
	16	1.73	2.68	1.92	3.01	2.39	3.81	4.09	3.68	4.26	
	24	1.61	2.55	1.80	2.88	2.30	3.73	4.00	3.62	4.19	
9	12	1.65	2.52	1.85	2.87	2.39	3.82	4.06	3.69	4.26	
	16	1.57	2.44	1.77	2.79	2.34	3.76	4.00	3.65	4.22	
	24	1.42	2.28	1.63	2.63	2.23	3.65	3.89	3.57	4.14	
10	12	1.48	2.27	1.70	2.65	2.34	3.77	3.96	3.66	4.23	
	16	1.39	2.17	1.61	2.55	2.28	3.70	3.89	3.61	4.18	
	24	1.22	1.99	1.44	2.36	2.14	3.55	3.75	3.52	4.08	
12	12	1.15	1.78	1.37	2.14	2.17	3.54	3.71	3.59	4.15	
	16	1.04 <sup>5</sup>	1.67	1.26	2.02	2.07	3.43	3.61	3.52	4.08	
	24	0.84 <sup>4</sup>	1.45 <sup>4</sup>	1.05 <sup>4</sup>	1.79	1.88	3.23	3.40	3.38	3.92	
14	12	0.85 <sup>4</sup>	1.36	1.05 <sup>5</sup>	1.68	1.94	3.19	3.39	3.50	4.02	
	16	0.73 <sup>4</sup>	1.24 <sup>4</sup>	0.93 <sup>4</sup>	1.54 <sup>5</sup>	1.81	3.05	3.25	3.40	3.91	
	24	0.53 <sup>3</sup>	1.01 <sup>4</sup>	0.71 <sup>3</sup>	1.30 <sup>4</sup>	1.57	2.79	2.98	3.20	3.69	
16	12	0.61 <sup>3</sup>	1.03 <sup>4</sup>	0.78 <sup>4</sup>	1.29 <sup>5</sup>	1.67	2.78	3.01	3.39	3.79	
	16	0.50 <sup>3</sup>	0.90 <sup>4</sup>	0.65 <sup>3</sup>	1.15 <sup>4</sup>	1.52	2.61	2.83	3.25	3.65	
	24	0.30 <sup>2</sup>	0.68 <sup>3</sup>	0.43 <sup>2</sup>	0.90 <sup>3</sup>	1.23 <sup>4</sup>	2.29	2.51	2.99	3.37	

		15 psf									
Wall Height (ft)	Spacing (in) on center	362SFS162-(mil)		400SFS162-(mil)		600SFS162-(mil)		600SFS200-(mil)	800SFS162-(mil)	800SFS200-(mil)	
		57 ksi		57 ksi		57 ksi		57 ksi	57 ksi	57 ksi	
		33EQS	43EQS	33EQS	43EQS	33EQS	43EQS	43EQS	43EQS	43EQS	
8	12	1.43	2.36	1.63	2.70	2.18	3.60	3.87	3.54	4.10	
	16	1.27	2.18	1.47	2.52	2.05	3.47	3.74	3.45	4.00	
	24	0.95 <sup>5</sup>	1.83	1.16	2.17	1.81	3.22	3.48	3.27	3.81	
9	12	1.21	2.05	1.42	2.41	2.07	3.48	3.72	3.46	4.01	
	16	1.02 <sup>5</sup>	1.84	1.23	2.19	1.91	3.32	3.55	3.35	3.89	
	24	0.66 <sup>4</sup>	1.45 <sup>5</sup>	0.86 <sup>4</sup>	1.79	1.61	2.99	3.22	3.12	3.64	
10	12	0.99 <sup>5</sup>	1.74	1.20	2.10	1.94	3.35	3.54	3.38	3.92	
	16	0.78 <sup>4</sup>	1.50 <sup>5</sup>	0.98 <sup>5</sup>	1.86	1.75	3.14	3.33	3.24	3.77	
	24	0.39 <sup>3</sup>	1.08 <sup>4</sup>	0.58 <sup>4</sup>	1.41 <sup>4</sup>	1.38	2.74	2.93	2.96	3.46	
12	12	0.59 <sup>4</sup>	1.17 <sup>4</sup>	0.78 <sup>4</sup>	1.49 <sup>5</sup>	1.60	2.93	3.11	3.17	3.69	
	16	0.36 <sup>3</sup>	0.92 <sup>4</sup>	0.53 <sup>4</sup>	1.21 <sup>4</sup>	1.34	2.65	2.82	2.97	3.47	
	24	-	0.47 <sup>3</sup>	0.09 <sup>3</sup>	0.72 <sup>3</sup>	0.85 <sup>5</sup>	2.11	2.28	2.57	3.02	
14	12	0.28 <sup>3</sup>	0.73 <sup>3</sup>	0.42 <sup>3</sup>	0.97 <sup>4</sup>	1.22	2.41	2.60	2.92	3.38	
	16	0.05 <sup>2</sup>	0.48 <sup>3</sup>	0.17 <sup>2</sup>	0.69 <sup>3</sup>	0.90 <sup>5</sup>	2.06	2.24	2.64	3.07	
	24	-	0.04 <sup>2</sup>	-	0.20 <sup>2</sup>	0.32 <sup>4</sup>	1.41 <sup>4</sup>	1.58 <sup>5</sup>	2.10	2.49	
16	12	0.06 <sup>2</sup>	0.40 <sup>2</sup>	0.15 <sup>2</sup>	0.59 <sup>3</sup>	0.84 <sup>4</sup>	1.86	2.06	2.62	2.97	
	16	-	0.16 <sup>2</sup>	-	0.31 <sup>2</sup>	0.49 <sup>4</sup>	1.47 <sup>4</sup>	1.65 <sup>5</sup>	2.26	2.59	
	24	-	-	-	-	0.77 <sup>4</sup>	0.92 <sup>4</sup>	1.59 <sup>5</sup>	1.87		

If no note, deflection is less than L/720.

<sup>1</sup>Deflection exceeds L/120

<sup>2</sup>Deflection exceeds L/240

<sup>3</sup>Deflection exceeds L/360

<sup>4</sup>Deflection exceeds L/600

<sup>5</sup>Deflection exceeds L/720

20 psf										
Wall Height (ft)	Spacing (in) on center	362SFS162-(mil)		400SFS162-(mil)		600SFS162-(mil)		600SFS200-(mil)	800SFS162-(mil)	800SFS200-(mil)
		57 ksi		57 ksi		57 ksi		57 ksi	57 ksi	57 ksi
		33EQS	43EQS	33EQS	43EQS	33EQS	43EQS	43EQS	43EQS	43EQS
8	12	1.27	2.18	1.47	2.52	2.05	3.47	3.74	3.45	4.00
	16	1.06	1.95	1.26	2.29	1.89	3.30	3.57	3.33	3.87
	24	0.66 <sup>4</sup>	1.51 <sup>5</sup>	0.86 <sup>5</sup>	1.85	1.57	2.97	3.23	3.10	3.61
9	12	1.02 <sup>5</sup>	1.84	1.23	2.19	1.91	3.32	3.55	3.35	3.89
	16	0.78 <sup>4</sup>	1.58	0.98 <sup>5</sup>	1.92	1.71	3.10	3.33	3.20	3.73
	24	0.34 <sup>3</sup>	1.09 <sup>4</sup>	0.53 <sup>4</sup>	1.41 <sup>5</sup>	1.31	2.68	2.90	2.90	3.40
10	12	0.78 <sup>4</sup>	1.50 <sup>5</sup>	0.98 <sup>5</sup>	1.86	1.75	3.14	3.33	3.24	3.77
	16	0.52 <sup>4</sup>	1.22 <sup>4</sup>	0.71 <sup>4</sup>	1.55 <sup>5</sup>	1.50	2.87	3.06	3.05	3.56
	24	0.05 <sup>3</sup>	0.70 <sup>3</sup>	0.21 <sup>3</sup>	0.99 <sup>4</sup>	1.02	2.36	2.55	2.68	3.16
12	12	0.36 <sup>3</sup>	0.92 <sup>4</sup>	0.53 <sup>4</sup>	1.21 <sup>4</sup>	1.34	2.65	2.82	2.97	3.47
	16	0.09 <sup>2</sup>	0.61 <sup>3</sup>	0.23 <sup>3</sup>	0.87 <sup>4</sup>	1.01	2.28	2.45	2.70	3.17
	24	-	0.08 <sup>2</sup>	-	0.28 <sup>3</sup>	0.39 <sup>4</sup>	1.60 <sup>5</sup>	1.76	2.18	2.59
14	12	0.05 <sup>2</sup>	0.48 <sup>3</sup>	0.17 <sup>2</sup>	0.69 <sup>3</sup>	0.90 <sup>3</sup>	2.06	2.24	2.64	3.07
	16	-	0.18 <sup>2</sup>	-	0.36 <sup>3</sup>	0.51 <sup>4</sup>	1.62 <sup>5</sup>	1.79 <sup>5</sup>	2.28	2.68
	24	-	-	-	-	-	0.83 <sup>4</sup>	0.98 <sup>4</sup>	1.59	1.92
16	12	-	0.16 <sup>2</sup>	-	0.31 <sup>2</sup>	0.49 <sup>4</sup>	1.47 <sup>4</sup>	1.65 <sup>5</sup>	2.26	2.59
	16	-	-	-	-	0.06 <sup>3</sup>	0.99 <sup>4</sup>	1.15 <sup>4</sup>	1.81	2.10
	24	-	-	-	-	-	0.15 <sup>3</sup>	0.26 <sup>3</sup>	0.96 <sup>4</sup>	1.19 <sup>5</sup>

25 psf										
Wall Height (ft)	Spacing (in) on center	362SFS162-(mil)		400SFS162-(mil)		600SFS162-(mil)		600SFS200-(mil)	800SFS162-(mil)	800SFS200-(mil)
		57 ksi		57 ksi		57 ksi		57 ksi	57 ksi	57 ksi
		33EQS	43EQS	33EQS	43EQS	33EQS	43EQS	43EQS	43EQS	43EQS
8	12	1.11	2.00	1.31	2.34	1.93	3.34	3.61	3.36	3.90
	16	0.85 <sup>5</sup>	1.73	1.06	2.06	1.73	3.13	3.40	3.21	3.74
	24	0.39 <sup>4</sup>	1.21 <sup>4</sup>	0.58 <sup>4</sup>	1.54 <sup>5</sup>	1.34	2.72	2.97	2.92	3.42
9	12	0.84 <sup>4</sup>	1.64	1.04 <sup>5</sup>	1.99	1.76	3.15	3.39	3.24	3.77
	16	0.55 <sup>4</sup>	1.33 <sup>4</sup>	0.75 <sup>4</sup>	1.66	1.51	2.89	3.12	3.05	3.56
	24	0.04 <sup>3</sup>	0.75 <sup>4</sup>	0.21 <sup>3</sup>	1.06 <sup>4</sup>	1.02	2.37	2.59	2.68	3.16
10	12	0.58 <sup>4</sup>	1.29 <sup>4</sup>	0.78 <sup>4</sup>	1.62 <sup>5</sup>	1.56	2.94	3.13	3.10	3.61
	16	0.28 <sup>3</sup>	0.95 <sup>4</sup>	0.45 <sup>4</sup>	1.26 <sup>4</sup>	1.26	2.61	2.80	2.87	3.36
	24	-	0.35 <sup>3</sup>	-	0.62 <sup>3</sup>	0.68 <sup>3</sup>	1.99	2.17	2.41	2.86
12	12	0.15 <sup>3</sup>	0.69 <sup>3</sup>	0.30 <sup>3</sup>	0.95 <sup>4</sup>	1.09	2.37	2.54	2.76	3.24
	16	-	0.34 <sup>3</sup>	-	0.57 <sup>3</sup>	0.69 <sup>4</sup>	1.93	2.10	2.44	2.88
	24	-	-	-	-	-	1.13 <sup>4</sup>	1.28 <sup>4</sup>	1.80	2.17
14	12	-	0.25 <sup>2</sup>	-	0.44 <sup>3</sup>	0.61 <sup>4</sup>	1.73 <sup>5</sup>	1.90	2.37	2.78
	16	-	-	-	0.05 <sup>2</sup>	0.15 <sup>4</sup>	1.21 <sup>4</sup>	1.37 <sup>4</sup>	1.93	2.29
	24	-	-	-	-	-	0.29 <sup>3</sup>	0.41 <sup>4</sup>	1.10 <sup>5</sup>	1.38
16	12	-	-	-	0.07 <sup>2</sup>	0.16 <sup>3</sup>	1.11 <sup>4</sup>	1.27 <sup>4</sup>	1.92	2.22
	16	-	-	-	-	-	0.56 <sup>3</sup>	0.69 <sup>4</sup>	1.37 <sup>5</sup>	1.64
	24	-	-	-	-	-	-	-	0.37 <sup>4</sup>	0.56 <sup>4</sup>

30 psf										
Wall Height (ft)	Spacing (in) on center	362SFS162-(mil)		400SFS162-(mil)		600SFS162-(mil)		600SFS200-(mil)	800SFS162-(mil)	800SFS200-(mil)
		57 ksi		57 ksi		57 ksi		57 ksi	57 ksi	57 ksi
		33EQS	43EQS	33EQS	43EQS	33EQS	43EQS	43EQS	43EQS	43EQS
8	12	0.95 <sup>5</sup>	1.83	1.16	2.17	1.81	3.22	3.48	3.27	3.81
	16	0.66 <sup>4</sup>	1.51 <sup>5</sup>	0.86 <sup>5</sup>	1.85	1.57	2.97	3.23	3.10	3.61
	24	0.13 <sup>3</sup>	0.92 <sup>4</sup>	0.31 <sup>4</sup>	1.24 <sup>4</sup>	1.11	2.48	2.72	2.75	3.23
9	12	0.66 <sup>4</sup>	1.45 <sup>5</sup>	0.86 <sup>4</sup>	1.79	1.61	2.99	3.22	3.12	3.64
	16	0.34 <sup>3</sup>	1.09 <sup>4</sup>	0.53 <sup>4</sup>	1.41 <sup>5</sup>	1.31	2.68	2.90	2.90	3.40
	24	-	0.44 <sup>3</sup>	-	0.73 <sup>4</sup>	0.74	2.07	2.28	2.46	2.92
10	12	0.39 <sup>3</sup>	1.08 <sup>4</sup>	0.58 <sup>4</sup>	1.41 <sup>4</sup>	1.38	2.74	2.93	2.96	3.46
	16	0.05 <sup>3</sup>	0.70 <sup>3</sup>	0.21 <sup>3</sup>	0.99 <sup>4</sup>	1.02	2.36	2.55	2.68	3.16
	24	-	0.03 <sup>2</sup>	-	0.26 <sup>3</sup>	0.34 <sup>4</sup>	1.63	1.80	2.15	2.56
12	12	-	0.47 <sup>3</sup>	0.09 <sup>3</sup>	0.72 <sup>3</sup>	0.85 <sup>5</sup>	2.11	2.28	2.57	3.02
	16	-	0.08 <sup>2</sup>	-	0.28 <sup>3</sup>	0.39 <sup>4</sup>	1.60 <sup>5</sup>	1.76	2.18	2.59
	24	-	-	-	-	-	0.67 <sup>4</sup>	0.82 <sup>4</sup>	1.42	1.76
14	12	-	0.04 <sup>2</sup>	-	0.20 <sup>2</sup>	0.32 <sup>4</sup>	1.41 <sup>4</sup>	1.58 <sup>5</sup>	2.10	2.49
	16	-	-	-	-	-	0.83 <sup>4</sup>	0.98 <sup>4</sup>	1.59	1.92
	24	-	-	-	-	-	-	-	0.62 <sup>4</sup>	0.86 <sup>5</sup>
16	12	-	-	-	-	-	0.77 <sup>4</sup>	0.92 <sup>4</sup>	1.59 <sup>5</sup>	1.87
	16	-	-	-	-	-	0.15 <sup>3</sup>	0.26 <sup>3</sup>	0.96 <sup>4</sup>	1.19 <sup>5</sup>
	24	-	-	-	-	-	-	-	-	-

If no note, deflection is less than L/720.

<sup>1</sup>Deflection exceeds L/120

<sup>2</sup>Deflection exceeds L/240

<sup>3</sup>Deflection exceeds L/360

<sup>4</sup>Deflection exceeds L/600

<sup>5</sup>Deflection exceeds L/720

# Combined Axial and Lateral Loads

35 psf										
Wall Height (ft)	Spacing (in) on center	362SFS162-(mil)		400SFS162-(mil)		600SFS162-(mil)		600SFS200-(mil)	800SFS162-(mil)	800SFS200-(mil)
		57 ksi		57 ksi		57 ksi		57 ksi	57 ksi	57 ksi
		33EQS	43EQS	33EQS	43EQS	33EQS	43EQS	43EQS	43EQS	43EQS
8	12	0.80 <sup>4</sup>	1.67	1.01	2.01	1.69	3.09	3.35	3.18	3.71
	16	0.48 <sup>4</sup>	1.31 <sup>4</sup>	0.67 <sup>4</sup>	1.64	1.42	2.80	3.06	2.98	3.49
	24	-	0.64 <sup>4</sup>	0.06 <sup>4</sup>	0.95 <sup>4</sup>	0.88	2.24	2.48	2.58	3.04
9	12	0.50 <sup>4</sup>	1.27 <sup>4</sup>	0.69 <sup>4</sup>	1.60 <sup>5</sup>	1.46	2.84	3.06	3.01	3.52
	16	0.14 <sup>3</sup>	0.86 <sup>4</sup>	0.32 <sup>4</sup>	1.18 <sup>4</sup>	1.11	2.48	2.69	2.76	3.24
	24	-	0.15 <sup>3</sup>	-	0.41 <sup>3</sup>	0.46 <sup>5</sup>	1.78	1.98	2.25	2.68
10	12	0.22 <sup>3</sup>	0.88 <sup>4</sup>	0.39 <sup>4</sup>	1.20 <sup>4</sup>	1.20	2.55	2.74	2.82	3.31
	16	-	0.46 <sup>3</sup>	-	0.74 <sup>4</sup>	0.79	2.11	2.29	2.50	2.96
	24	-	-	-	-	0.02 <sup>4</sup>	1.28 <sup>5</sup>	1.45	1.88	2.27
12	12	-	0.27 <sup>2</sup>	-	0.49 <sup>3</sup>	0.62 <sup>4</sup>	1.85	2.02	2.37	2.81
	16	-	-	-	0.02 <sup>2</sup>	0.11 <sup>4</sup>	1.28 <sup>4</sup>	1.44 <sup>5</sup>	1.92	2.31
	24	-	-	-	-	-	0.24 <sup>4</sup>	0.37 <sup>4</sup>	1.06 <sup>5</sup>	1.36
14	12	-	-	-	-	0.06 <sup>3</sup>	1.12 <sup>4</sup>	1.27 <sup>4</sup>	1.84	2.20
	16	-	-	-	-	-	0.47 <sup>4</sup>	0.60 <sup>4</sup>	1.26 <sup>5</sup>	1.56
	24	-	-	-	-	-	-	-	0.17 <sup>4</sup>	0.36 <sup>4</sup>
16	12	-	-	-	-	-	0.45 <sup>3</sup>	0.58 <sup>3</sup>	1.27 <sup>5</sup>	1.52 <sup>5</sup>
	16	-	-	-	-	-	-	-	0.56 <sup>4</sup>	0.76 <sup>4</sup>
	24	-	-	-	-	-	-	-	-	-

40 psf										
Wall Height (ft)	Spacing (in) on center	362SFS162-(mil)		400SFS162-(mil)		600SFS162-(mil)		600SFS200-(mil)	800SFS162-(mil)	800SFS200-(mil)
		57 ksi		57 ksi		57 ksi		57 ksi	57 ksi	57 ksi
		33EQS	43EQS	33EQS	43EQS	33EQS	43EQS	43EQS	43EQS	43EQS
8	12	0.66 <sup>4</sup>	1.51 <sup>5</sup>	0.86 <sup>5</sup>	1.85	1.57	2.97	3.23	3.10	3.61
	16	0.30 <sup>4</sup>	1.11 <sup>4</sup>	0.49 <sup>4</sup>	1.44 <sup>5</sup>	1.26	2.64	2.89	2.87	3.36
	24	-	0.38 <sup>3</sup>	-	0.68 <sup>4</sup>	0.66	2.01	2.23	2.41	2.85
9	12	0.34 <sup>3</sup>	1.09 <sup>4</sup>	0.53 <sup>4</sup>	1.41 <sup>5</sup>	1.31	2.68	2.90	2.90	3.40
	16	-	0.65 <sup>4</sup>	0.11 <sup>3</sup>	0.95 <sup>4</sup>	0.92	2.27	2.48	2.61	3.08
	24	-	-	-	0.11 <sup>3</sup>	0.19 <sup>4</sup>	1.49	1.68	2.03	2.44
10	12	0.05 <sup>3</sup>	0.70 <sup>3</sup>	0.21 <sup>3</sup>	0.99 <sup>4</sup>	1.02	2.36	2.55	2.68	3.16
	16	-	0.24 <sup>3</sup>	-	0.50 <sup>3</sup>	0.56 <sup>5</sup>	1.87	2.05	2.32	2.76
	24	-	-	-	-	-	0.94 <sup>4</sup>	1.10 <sup>5</sup>	1.62	1.98
12	12	-	0.08 <sup>2</sup>	-	0.28 <sup>3</sup>	0.39 <sup>4</sup>	1.60 <sup>5</sup>	1.76	2.18	2.59
	16	-	-	-	-	-	0.97 <sup>4</sup>	1.12 <sup>4</sup>	1.67	2.03
	24	-	-	-	-	-	-	-	0.70 <sup>5</sup>	0.96
14	12	-	-	-	-	-	0.83 <sup>4</sup>	0.98 <sup>4</sup>	1.59	1.92
	16	-	-	-	-	-	0.12 <sup>3</sup>	0.24 <sup>3</sup>	0.94 <sup>4</sup>	1.21 <sup>5</sup>
	24	-	-	-	-	-	-	-	-	-
16	12	-	-	-	-	-	0.15 <sup>3</sup>	0.26 <sup>3</sup>	0.96 <sup>4</sup>	1.19 <sup>5</sup>
	16	-	-	-	-	-	-	-	0.18 <sup>4</sup>	0.35 <sup>4</sup>
	24	-	-	-	-	-	-	-	-	-

50 psf										
Wall Height (ft)	Spacing (in) on center	362SFS162-(mil)		400SFS162-(mil)		600SFS162-(mil)		600SFS200-(mil)	800SFS162-(mil)	800SFS200-(mil)
		57 ksi		57 ksi		57 ksi		57 ksi	57 ksi	57 ksi
		33EQS	43EQS	33EQS	43EQS	33EQS	43EQS	43EQS	43EQS	43EQS
8	12	0.39 <sup>4</sup>	1.21 <sup>4</sup>	0.58 <sup>4</sup>	1.54 <sup>5</sup>	1.34	2.72	2.97	2.92	3.42
	16	-	0.74 <sup>4</sup>	0.14 <sup>4</sup>	1.05 <sup>4</sup>	0.96	2.32	2.56	2.64	3.10
	24	-	-	-	0.15 <sup>3</sup>	0.23 <sup>3</sup>	1.54	1.75	2.07	2.48
9	12	0.04 <sup>3</sup>	0.75 <sup>4</sup>	0.21 <sup>3</sup>	1.06 <sup>4</sup>	1.02	2.37	2.59	2.68	3.16
	16	-	0.24 <sup>3</sup>	-	0.52 <sup>4</sup>	0.55 <sup>5</sup>	1.88	2.08	2.32	2.76
	24	-	-	-	-	-	0.93 <sup>5</sup>	1.10 <sup>5</sup>	1.61	1.97
10	12	-	0.35 <sup>3</sup>	-	0.62 <sup>3</sup>	0.68 <sup>5</sup>	1.99	2.17	2.41	2.86
	16	-	-	-	0.04 <sup>3</sup>	0.13 <sup>4</sup>	1.40 <sup>5</sup>	1.57	1.97	2.37
	24	-	-	-	-	-	0.29 <sup>4</sup>	0.43 <sup>4</sup>	1.11	1.41
12	12	-	-	-	-	-	1.13 <sup>4</sup>	1.28 <sup>4</sup>	1.80	2.17
	16	-	-	-	-	-	0.38 <sup>4</sup>	0.52 <sup>4</sup>	1.18	1.49
	24	-	-	-	-	-	-	-	0.01 <sup>4</sup>	0.20 <sup>4</sup>
14	12	-	-	-	-	-	0.29 <sup>3</sup>	0.41 <sup>4</sup>	1.10 <sup>5</sup>	1.38
	16	-	-	-	-	-	-	-	0.32 <sup>4</sup>	0.52 <sup>4</sup>
	24	-	-	-	-	-	-	-	-	-
16	12	-	-	-	-	-	-	-	0.37 <sup>4</sup>	0.56 <sup>4</sup>
	16	-	-	-	-	-	-	-	-	-
	24	-	-	-	-	-	-	-	-	-

If no note, deflection is less than L/720.

<sup>1</sup>Deflection exceeds L/120

<sup>2</sup>Deflection exceeds L/240

<sup>3</sup>Deflection exceeds L/360

<sup>4</sup>Deflection exceeds L/600

<sup>5</sup>Deflection exceeds L/720

See Table Notes on page 22





## Table Notes

1. Values are for simple span conditions.
2. For unbraced sections, allowable moment is based on the AISI S100 Section C3.1.2 with unbraced length assumed to be the listed span. For mid-span braced sections, allowable moment is based on AISI S100 Section C3.1.2 with unbraced length assumed to be half of the listed span.
3. Web crippling check is based on 1" of bearing at end supports.
4. Web crippling and shear capacity have **not** been reduced for punchouts. If web punchouts occur near supports, members must be checked for reduced shear and web crippling in accordance with AISI S100.
5. See page 5 for additional table notes.

Deflection Limit L/240 - Ceiling Spans																			
Part No.	F <sub>y</sub> (ksi)	4 psf						6 psf						13 psf*					
		Lateral Support of Compression Flange						Lateral Support of Compression Flange						Lateral Support of Compression Flange					
		Unsupported			Midspan			Unsupported			Midspan			Unsupported			Midspan		
		Joist Spacing (in) oc			Joist Spacing (in) oc			Joist Spacing (in) oc			Joist Spacing (in) oc			Joist Spacing (in) oc			Joist Spacing (in) oc		
		12	16	24	12	16	24	12	16	24	12	16	24	12	16	24	12	16	24
162SFS-D20	57	7' 4"	6' 8"	5' 10"	7' 4"	6' 8"	5' 10"	6' 5"	5' 10"	5' 1"	6' 5"	5' 10"	5' 1"	4' 11"	4' 6"	3' 11"	4' 11"	4' 6"	3' 11"
162SFS-30EQD	57	9' 5"	8' 7"	7' 6"	9' 5"	8' 7"	7' 6"	8' 3"	7' 6"	6' 6"	8' 3"	7' 6"	6' 6"	6' 4"	5' 9"	5' 0"	6' 4"	5' 9"	5' 0"
162SFS-33EQD	57	9' 5"	8' 7"	7' 6"	9' 5"	8' 7"	7' 6"	8' 3"	7' 6"	6' 6"	8' 3"	7' 6"	6' 6"	6' 4"	5' 9"	5' 0"	6' 4"	5' 9"	5' 0"
250SFS-D20	57	9' 5"	8' 9"	7' 10"	12' 2"	11' 1"	9' 8"	8' 6"	7' 10"	6' 11"	10' 7"	9' 8"	8' 5"	6' 9"	6' 2"	5' 6"	8' 2"	7' 5"	6' 6"
250SFS-30EQD	57	10' 7"	9' 10"	8' 10"	13' 1"	11' 11"	10' 5"	9' 6"	8' 10"	7' 11"	11' 5"	10' 5"	9' 1"	7' 9"	7' 2"	6' 5"	8' 10"	8' 0"	7' 0"
250SFS-33EQD	57	10' 7"	9' 10"	8' 10"	13' 1"	11' 11"	10' 5"	9' 6"	8' 10"	7' 11"	11' 5"	10' 5"	9' 1"	7' 9"	7' 2"	6' 5"	8' 10"	8' 0"	7' 0"
350SFS-D20	57	10' 5"	9' 8"	8' 8"	14' 7"	13' 4"	11' 10"	9' 4"	8' 8"	7' 9"	12' 10"	11' 10"	10' 4"	7' 6"	6' 11"	6' 1"	10' 0"	9' 0"	6' 6"
350SFS-30EQD	57	11' 6"	10' 8"	9' 7"	16' 6"	15' 2"	13' 5"	10' 4"	9' 7"	8' 7"	14' 8"	13' 5"	11' 10"	8' 5"	7' 9"	6' 11"	11' 6"	10' 5"	9' 0"
350SFS-33EQD	57	11' 6"	10' 8"	9' 7"	16' 6"	15' 2"	13' 5"	10' 4"	9' 7"	8' 7"	14' 8"	13' 5"	11' 10"	8' 5"	7' 9"	6' 11"	11' 6"	10' 5"	9' 0"
362SFS-D20	57	10' 6"	9' 9"	8' 10"	14' 8"	13' 6"	11' 11"	9' 6"	8' 10"	7' 10"	13' 0"	11' 11"	10' 5"	7' 7"	7' 0"	6' 2"	10' 2"	9' 2"	6' 6"
362SFS-30EQD	57	11' 7"	10' 9"	9' 8"	16' 7"	15' 4"	13' 7"	10' 5"	9' 8"	8' 8"	14' 10"	13' 7"	12' 0"	8' 6"	7' 10"	7' 0"	11' 9"	10' 8"	9' 2"
362SFS-33EQD	57	11' 7"	10' 9"	9' 8"	16' 7"	15' 4"	13' 7"	10' 5"	9' 8"	8' 8"	14' 10"	13' 7"	12' 0"	8' 6"	7' 10"	7' 0"	11' 9"	10' 8"	9' 2"
400SFS-D20	57	10' 10"	10' 1"	9' 0"	15' 0"	13' 9"	12' 2"	9' 9"	9' 0"	8' 0"	13' 3"	12' 2"	10' 8"	7' 9"	7' 2"	6' 4"	10' 5"	9' 5"	8' 0"
400SFS-30EQD	57	11' 11"	11' 0"	9' 11"	17' 0"	15' 9"	14' 0"	10' 8"	9' 11"	8' 11"	15' 3"	14' 0"	12' 5"	8' 8"	8' 1"	7' 2"	12' 1"	11' 1"	9' 7"
400SFS-33EQD	57	11' 11"	11' 0"	9' 11"	17' 0"	15' 9"	14' 0"	10' 8"	9' 11"	8' 11"	15' 3"	14' 0"	12' 5"	8' 8"	8' 1"	7' 2"	12' 1"	11' 1"	9' 7"
550SFS-30EQD	57	13' 3"	12' 4"	11' 1"	19' 3"	17' 11"	16' 2"	11' 11"	11' 1"	10' 0"	17' 5"	16' 2"	14' 6"	9' 10"	9' 1"	8' 3"	14' 1"	12' 4"	8' 3"
550SFS-33EQD	57	13' 3"	12' 4"	11' 1"	19' 3"	17' 11"	16' 2"	11' 11"	11' 1"	10' 0"	17' 5"	16' 2"	14' 6"	9' 10"	9' 1"	8' 3"	14' 1"	12' 4"	8' 3"
600SFS-30EQD	57	13' 7"	12' 7"	11' 4"	19' 5"	18' 0"	16' 2"	12' 3"	11' 4"	10' 2"	17' 5"	16' 2"	14' 5"	9' 11"	9' 2"	8' 3"	14' 1"	12' 4"	8' 3"
600SFS-33EQD	57	13' 7"	12' 7"	11' 4"	19' 5"	18' 0"	16' 2"	12' 3"	11' 4"	10' 2"	17' 5"	16' 2"	14' 5"	9' 11"	9' 2"	8' 3"	14' 1"	12' 4"	8' 3"

Deflection Limit L/360 - Ceiling Spans																			
Part No.	F <sub>y</sub> (ksi)	4 psf						6 psf						13 psf*					
		Lateral Support of Compression Flange						Lateral Support of Compression Flange						Lateral Support of Compression Flange					
		Unsupported			Midspan			Unsupported			Midspan			Unsupported			Midspan		
		Joist Spacing (in) oc			Joist Spacing (in) oc			Joist Spacing (in) oc			Joist Spacing (in) oc			Joist Spacing (in) oc			Joist Spacing (in) oc		
		12	16	24	12	16	24	12	16	24	12	16	24	12	16	24	12	16	24
162SFS-D20	57	6' 5"	5' 10"	5' 1"	6' 5"	5' 10"	5' 1"	5' 7"	5' 1"	4' 5"	5' 7"	5' 1"	4' 5"	4' 4"	3' 11"	3' 5"	4' 4"	3' 11"	3' 5"
162SFS-30EQD	57	8' 3"	7' 6"	6' 6"	8' 3"	7' 6"	6' 6"	7' 2"	6' 6"	5' 8"	7' 2"	6' 6"	5' 8"	5' 7"	5' 0"	4' 5"	5' 7"	5' 0"	4' 5"
162SFS-33EQD	57	8' 3"	7' 6"	6' 6"	8' 3"	7' 6"	6' 6"	7' 2"	6' 6"	5' 8"	7' 2"	6' 6"	5' 8"	5' 7"	5' 0"	4' 5"	5' 7"	5' 0"	4' 5"
250SFS-D20	57	9' 5"	8' 9"	7' 10"	10' 7"	9' 8"	8' 5"	8' 6"	7' 10"	6' 11"	9' 3"	8' 5"	7' 4"	6' 9"	6' 2"	5' 6"	7' 2"	6' 6"	5' 8"
250SFS-30EQD	57	10' 7"	9' 10"	8' 10"	11' 5"	10' 5"	9' 1"	9' 6"	8' 10"	7' 11"	10' 0"	9' 1"	7' 11"	7' 9"	7' 0"	6' 1"	7' 9"	7' 0"	6' 1"
250SFS-33EQD	57	10' 7"	9' 10"	8' 10"	11' 5"	10' 5"	9' 1"	9' 6"	8' 10"	7' 11"	10' 0"	9' 1"	7' 11"	7' 9"	7' 0"	6' 1"	7' 9"	7' 0"	6' 1"
350SFS-D20	57	10' 5"	9' 8"	8' 8"	13' 8"	12' 5"	10' 10"	9' 4"	8' 8"	7' 9"	11' 11"	10' 10"	9' 6"	7' 6"	6' 11"	6' 1"	9' 3"	8' 5"	6' 6"
350SFS-30EQD	57	11' 6"	10' 8"	9' 7"	14' 11"	13' 6"	11' 10"	10' 4"	9' 7"	8' 7"	13' 0"	11' 10"	10' 4"	8' 5"	7' 9"	6' 11"	10' 0"	9' 1"	7' 11"
350SFS-33EQD	57	11' 6"	10' 8"	9' 7"	14' 11"	13' 6"	11' 10"	10' 4"	9' 7"	8' 7"	13' 0"	11' 10"	10' 4"	8' 5"	7' 9"	6' 11"	10' 0"	9' 1"	7' 11"
362SFS-D20	57	10' 6"	9' 9"	8' 10"	14' 0"	12' 9"	11' 2"	9' 6"	8' 10"	7' 10"	12' 3"	11' 2"	9' 9"	7' 7"	7' 0"	6' 2"	9' 6"	8' 7"	6' 6"
362SFS-30EQD	57	11' 7"	10' 9"	9' 8"	15' 4"	13' 11"	12' 2"	10' 5"	9' 8"	8' 8"	13' 4"	12' 2"	10' 7"	8' 6"	7' 10"	7' 0"	10' 4"	9' 4"	8' 2"
362SFS-33EQD	57	11' 7"	10' 9"	9' 8"	15' 4"	13' 11"	12' 2"	10' 5"	9' 8"	8' 8"	13' 4"	12' 2"	10' 7"	8' 6"	7' 10"	7' 0"	10' 4"	9' 4"	8' 2"
400SFS-D20	57	10' 10"	10' 1"	9' 0"	14' 10"	13' 6"	11' 9"	9' 9"	9' 0"	8' 0"	13' 0"	11' 9"	10' 4"	7' 9"	7' 2"	6' 4"	10' 0"	9' 1"	8' 0"
400SFS-30EQD	57	11' 11"	11' 0"	9' 11"	16' 6"	15' 0"	13' 1"	10' 8"	9' 11"	8' 11"	14' 5"	13' 1"	11' 5"	8' 8"	8' 1"	7' 2"	11' 2"	10' 2"	8' 10"
400SFS-33EQD	57	11' 11"	11' 0"	9' 11"	16' 6"	15' 0"	13' 1"	10' 8"	9' 11"	8' 11"	14' 5"	13' 1"	11' 5"	8' 8"	8' 1"	7' 2"	11' 2"	10' 2"	8' 10"
550SFS-30EQD	57	13' 3"	12' 4"	11' 1"	19' 3"	17' 11"	16' 2"	11' 11"	11' 1"	10' 0"	17' 5"	16' 2"	14' 6"	9' 10"	9' 1"	8' 3"	14' 1"	12' 4"	8' 3"
550SFS-33EQD	57	13' 3"	12' 4"	11' 1"	19' 3"	17' 11"	16' 2"	11' 11"	11' 1"	10' 0"	17' 5"	16' 2"	14' 6"	9' 10"	9' 1"	8' 3"	14' 1"	12' 4"	8' 3"
600SFS-30EQD	57	13' 7"	12' 7"	11' 4"	19' 5"	18' 0"	16' 2"	12' 3"	11' 4"	10' 2"	17' 5"	16' 2"	14' 5"	9' 11"	9' 2"	8' 3"	14' 1"	12' 4"	8' 3"
600SFS-33EQD	57	13' 7"	12' 7"	11' 4"	19' 5"	18' 0"	16' 2"	12' 3"	11' 4"	10' 2"	17' 5"	16' 2"	14' 5"	9' 11"	9' 2"	8' 3"	14' 1"	12' 4"	8' 3"

\*Loads that exceed 10 psf limit require a G60 galvanized coating.  
 "e" Web stiffeners required at ends.

## Mid-Span Ceiling Bracing Details

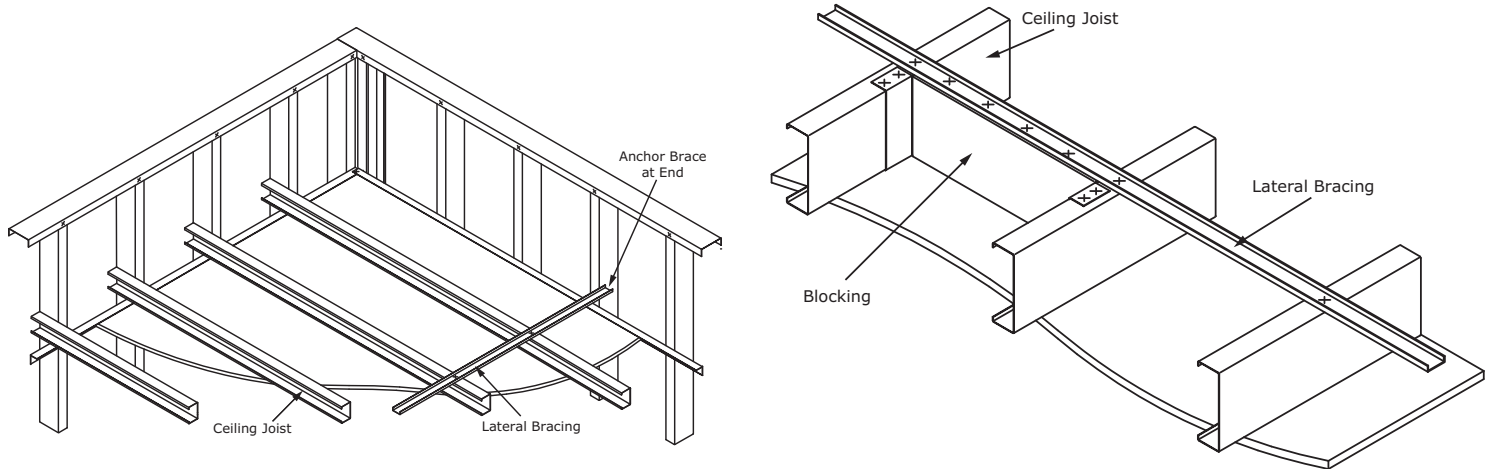

**General Note:**  
All connections should be designed by a licensed design professional.

## Hat Channel Section Properties

### Table Notes

1. If present, hems and offsets in flanges are ignored.
2. Effective properties are given as the minimum value for positive or negative bending.
3. See page 5 for additional table notes.

SFS (Hat) Furring (F) Channel Section Properties

Part No.	F <sub>y</sub> (ksi)	Design Thickness (in)	Gross Properties					Effective Properties			
			Area (in <sup>2</sup> )	Weight (lb/ft)	I <sub>x</sub> (in <sup>4</sup> )	R <sub>x</sub> (in)	I <sub>y</sub> (in <sup>4</sup> )	R <sub>y</sub> (in)	I <sub>x</sub> (in <sup>4</sup> )	S <sub>x</sub> (in <sup>3</sup> )	M <sub>a</sub> (ft-lb)
087F125-D20	57	0.0188	0.070	0.239	0.009	0.357	0.0354	0.711	0.0080	0.0146	41.39
087F125-30EQD	57	0.0235	0.087	0.297	0.011	0.355	0.0441	0.711	0.0104	0.0195	55.41
087F125-33EQD	57	0.0235	0.087	0.297	0.011	0.355	0.0441	0.711	0.0104	0.0195	55.41
087F125-33EQS	57	0.0295	0.109	0.370	0.014	0.353	0.0550	0.711	0.0135	0.0262	74.39
087F125-43EQS	57	0.0400	0.145	0.495	0.018	0.350	0.0734	0.711	0.0178	0.0381	108.48
150F125-30EQD	57	0.0235	0.117	0.398	0.038	0.574	0.0581	0.705	0.0368	0.0421	119.63
150F125-33EQD	57	0.0235	0.117	0.398	0.038	0.574	0.0581	0.705	0.0368	0.0421	119.63
150F125-33EQS	57	0.0295	0.146	0.497	0.048	0.572	0.0726	0.705	0.0472	0.0557	158.43
150F125-43EQS	57	0.0400	0.196	0.667	0.063	0.568	0.0974	0.705	0.0631	0.0802	228.11

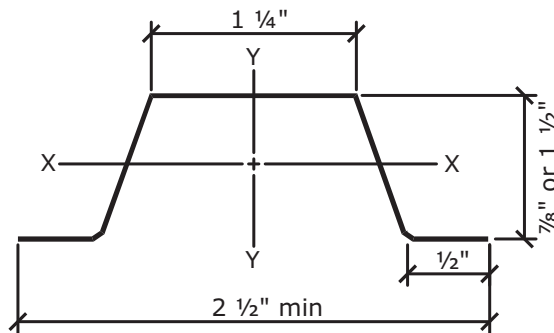

## Table Notes

1. Web crippling check is based on 1" of bearing at end and interior supports.
2. Single spans are the minimum span based on moment, shear, web crippling, or deflection.
3. Multiple spans indicate two or more equal and continuous spans with span length measured support to support.
4. Multiple spans are the minimum spans based on moment, shear, web crippling, deflection, combined bending and shear, or combined bending and web crippling.
5. See page 5 for additional table notes.

SFS (Hat) Furring (F) Channel Allowable Ceiling Spans L/240											
Part No.	F <sub>y</sub> (ksi)	Spans	4 psf			6 psf			13 psf *		
			Spacing (in) on center			Spacing (in) on center			Spacing (in) on center		
			12	16	24	12	16	24	12	16	24
087F125-D20	57	Single	5' 1"	4' 7"	4' 0"	4' 5"	4' 0"	3' 6"	3' 5"	3' 1"	2' 9"
		Multiple	6' 4"	5' 9"	5' 0"	5' 6"	5' 0"	4' 4"	4' 3"	3' 10"	3' 4"
087F125-30EQD	57	Single	5' 7"	5' 1"	4' 5"	4' 10"	4' 5"	3' 10"	3' 9"	3' 5"	3' 0"
		Multiple	6' 10"	6' 3"	5' 5"	6' 0"	5' 5"	4' 9"	4' 8"	4' 3"	3' 8"
087F125-33EQD	57	Single	5' 7"	5' 1"	4' 5"	4' 10"	4' 5"	3' 10"	3' 9"	3' 5"	3' 0"
		Multiple	6' 10"	6' 3"	5' 5"	6' 0"	5' 5"	4' 9"	4' 8"	4' 3"	3' 8"
087F125-33EQS	57	Single	6' 1"	5' 6"	4' 10"	5' 3"	4' 10"	4' 2"	4' 1"	3' 9"	3' 3"
		Multiple	7' 6"	6' 10"	5' 11"	6' 6"	5' 11"	5' 2"	5' 1"	4' 7"	4' 0"
087F125-43EQS	57	Single	6' 8"	6' 0"	5' 3"	5' 10"	5' 3"	4' 7"	4' 6"	4' 1"	3' 7"
		Multiple	8' 2"	7' 5"	6' 6"	7' 2"	6' 6"	5' 8"	5' 6"	5' 0"	4' 5"
150F125-30EQD	57	Single	8' 5"	7' 8"	6' 8"	7' 5"	6' 8"	5' 10"	5' 8"	5' 2"	4' 6"
		Multiple	10' 5"	9' 6"	8' 4"	9' 2"	8' 4"	7' 3"	7' 1"	6' 5"	5' 7"
150F125-33EQD	57	Single	8' 5"	7' 8"	6' 8"	7' 5"	6' 8"	5' 10"	5' 8"	5' 2"	4' 6"
		Multiple	10' 5"	9' 6"	8' 4"	9' 2"	8' 4"	7' 3"	7' 1"	6' 5"	5' 7"
150F125-33EQS	57	Single	9' 2"	8' 4"	7' 3"	8' 0"	7' 3"	6' 4"	6' 2"	5' 8"	4' 11"
		Multiple	11' 4"	10' 4"	9' 0"	9' 11"	9' 0"	7' 10"	7' 8"	7' 0"	6' 1"
150F125-43EQS	57	Single	10' 1"	9' 2"	8' 0"	8' 10"	8' 0"	7' 0"	6' 10"	6' 2"	5' 5"
		Multiple	12' 6"	11' 4"	9' 11"	10' 11"	9' 11"	8' 8"	8' 5"	7' 8"	6' 8"

SFS (Hat) Furring (F) Channel Allowable Ceiling Spans L/360											
Part No.	F <sub>y</sub> (ksi)	Spans	4 psf			6 psf			13 psf *		
			Spacing (in) on center			Spacing (in) oc			Spacing (in) oc		
			12	16	24	12	16	24	12	16	24
087F125-D20	57	Single	4' 5"	4' 0"	3' 6"	3' 11"	3' 6"	3' 1"	3' 0"	2' 9"	2' 5"
		Multiple	5' 6"	5' 0"	4' 4"	4' 10"	4' 4"	3' 10"	3' 9"	3' 4"	2' 11"
087F125-30EQD	57	Single	4' 10"	4' 5"	3' 10"	4' 3"	3' 10"	3' 4"	3' 3"	3' 0"	2' 7"
		Multiple	6' 0"	5' 5"	4' 9"	5' 3"	4' 9"	4' 2"	4' 1"	3' 8"	3' 3"
087F125-33EQD	57	Single	4' 10"	4' 5"	3' 10"	4' 3"	3' 10"	3' 4"	3' 3"	3' 0"	2' 7"
		Multiple	6' 0"	5' 5"	4' 9"	5' 3"	4' 9"	4' 2"	4' 1"	3' 8"	3' 3"
087F125-33EQS	57	Single	5' 3"	4' 10"	4' 2"	4' 7"	4' 2"	3' 8"	3' 7"	3' 3"	2' 10"
		Multiple	6' 6"	5' 11"	5' 2"	5' 9"	5' 2"	4' 6"	4' 5"	4' 0"	3' 6"
087F125-43EQS	57	Single	5' 10"	5' 3"	4' 7"	5' 1"	4' 7"	4' 0"	3' 11"	3' 7"	3' 1"
		Multiple	7' 2"	6' 6"	5' 8"	6' 3"	5' 8"	5' 0"	4' 10"	4' 5"	3' 10"
150F125-30EQD	57	Single	7' 5"	6' 8"	5' 10"	6' 5"	5' 10"	5' 1"	5' 0"	4' 6"	3' 11"
		Multiple	9' 2"	8' 4"	7' 3"	8' 0"	7' 3"	6' 4"	6' 2"	5' 7"	4' 11"
150F125-33EQD	57	Single	7' 5"	6' 8"	5' 10"	6' 5"	5' 10"	5' 1"	5' 0"	4' 6"	3' 11"
		Multiple	9' 2"	8' 4"	7' 3"	8' 0"	7' 3"	6' 4"	6' 2"	5' 7"	4' 11"
150F125-33EQS	57	Single	8' 0"	7' 3"	6' 4"	7' 0"	6' 4"	5' 7"	5' 5"	4' 11"	4' 4"
		Multiple	9' 11"	9' 0"	7' 10"	8' 8"	7' 10"	6' 11"	6' 8"	6' 1"	5' 4"
150F125-43EQS	57	Single	8' 10"	8' 0"	7' 0"	7' 9"	7' 0"	6' 2"	6' 0"	5' 5"	4' 9"
		Multiple	10' 11"	9' 11"	8' 8"	9' 7"	8' 8"	7' 7"	7' 5"	6' 8"	5' 10"

\*Loads that exceed 10 psf limit require a G60 galvanized coating.

## Table Notes

1. Listed allowable loads apply only to S-Sections.
2. Listed allowable loads are based on members fastened to supports.
3. "h" refers to the flat dimension of the web. See Web Depth-to-Thickness Ratios table on page 7.
4. Listed allowable loads are for unpunched webs. Capacity reductions for end and interior one flange loading (conditions 1 and 2) near punchouts may be calculated per AISI S100 Specification Section C3.4.2.
5. See page 5 for additional table notes.

## Allowable Loads (lbs) - Single Members

Section (h)	Design Thickness (in)	Thickness (mil)	F <sub>y</sub> (ksi)	Condition 1			Condition 2			Condition 3			Condition 4		
				Fasten to Support			Fasten to Support			Fasten to Support			Fasten to Support		
				Bearing Length (in)			Bearing Length (in)			Bearing Length (in)			Bearing Length (in)		
1	3.5	6	1	3.5	6	1	3.5	6	1	3.5	6	1	3.5	6	
162	0.0188	D20	57	95	155	194	150	216	260	78	110	131	210	277	322
162	0.0235	30EQD	57	147	237	296	250	353	422	128	177	210	338	439	506
162	0.0235	33EQD	57	147	237	296	250	353	422	128	177	210	338	439	506
250	0.0188	D20	57	90	146	183	146	211	254	63	89	106	189	250	290
250	0.0235	30EQD	57	140	225	281	244	345	413	108	149	176	309	401	463
250	0.0235	33EQD	57	140	225	281	244	345	413	108	149	176	309	401	463
250	0.0295	33EQS	57	219	347	432	403	561	666	181	246	289	505	645	738
250	0.0400	43EQS	57	396	615	761	783	1063	1250	356	473	550	969	1210	1370
350	0.0188	D20	57	85	138	173	143	206	247	49	69	82	169	224	260
350	0.0235	30EQD	57	133	214	267	239	338	404	88	122	145	282	366	422
350	0.0235	33EQD	57	133	214	267	239	338	404	88	122	145	282	366	422
350	0.0295	33EQS	57	209	332	413	396	550	653	155	210	247	468	597	683
350	0.0400	43EQS	57	382	593	734	770	1046	1230	316	419	488	910	1136	1286
362	0.0188	D20	57	84	137	142	142	205	247	47	67	80	167	221	257
362	0.0235	30EQD	57	132	213	266	238	337	403	86	119	141	279	362	417
362	0.0235	33EQD	57	132	213	266	238	337	403	86	119	141	279	362	417
362	0.0295	33EQS	57	208	330	411	395	549	652	152	206	243	463	592	677
362	0.0400	43EQS	57	380	591	731	769	1044	1227	311	413	481	903	1128	1277
400	0.0235	30EQD	57	130	209	261	236	334	400	80	110	131	270	351	404
400	0.0235	33EQD	57	130	209	261	236	334	400	80	110	131	270	351	404
400	0.0295	33EQS	57	205	325	405	392	546	648	143	195	229	451	576	659
400	0.0400	43EQS	57	376	584	722	764	1039	1221	298	395	460	884	1103	1249
550 <sup>1</sup>	0.0235	30EQD	57	122	196	245	230	326	389	57	79	94	238	309	357
550 <sup>1</sup>	0.0235	33EQD	57	122	196	245	230	326	389	57	79	94	238	309	357
550	0.0295	33EQS	57	194	308	384	383	533	633	112	152	179	407	519	594
550	0.0400	43EQS	57	359	558	690	749	1018	1197	251	332	387	814	1017	1151
600 <sup>1</sup>	0.0235	30EQD	57	107	192	240	228	323	386	50	70	83	229	297	342
600 <sup>1</sup>	0.0235	33EQD	57	107	192	240	228	323	386	50	70	83	229	297	342
600	0.0295	33EQS	57	191	303	377	380	529	628	103	140	164	393	502	574
600	0.0400	43EQS	57	354	550	681	745	1012	1190	236	314	365	793	991	1122
800	0.0400	43EQS	57	336	522	646	729	990	1164	185	245	285	718	897	1015

<sup>1</sup>Bearing length to web height ratio, N/h exceeds limit of 2.

## Web Crippling Conditions

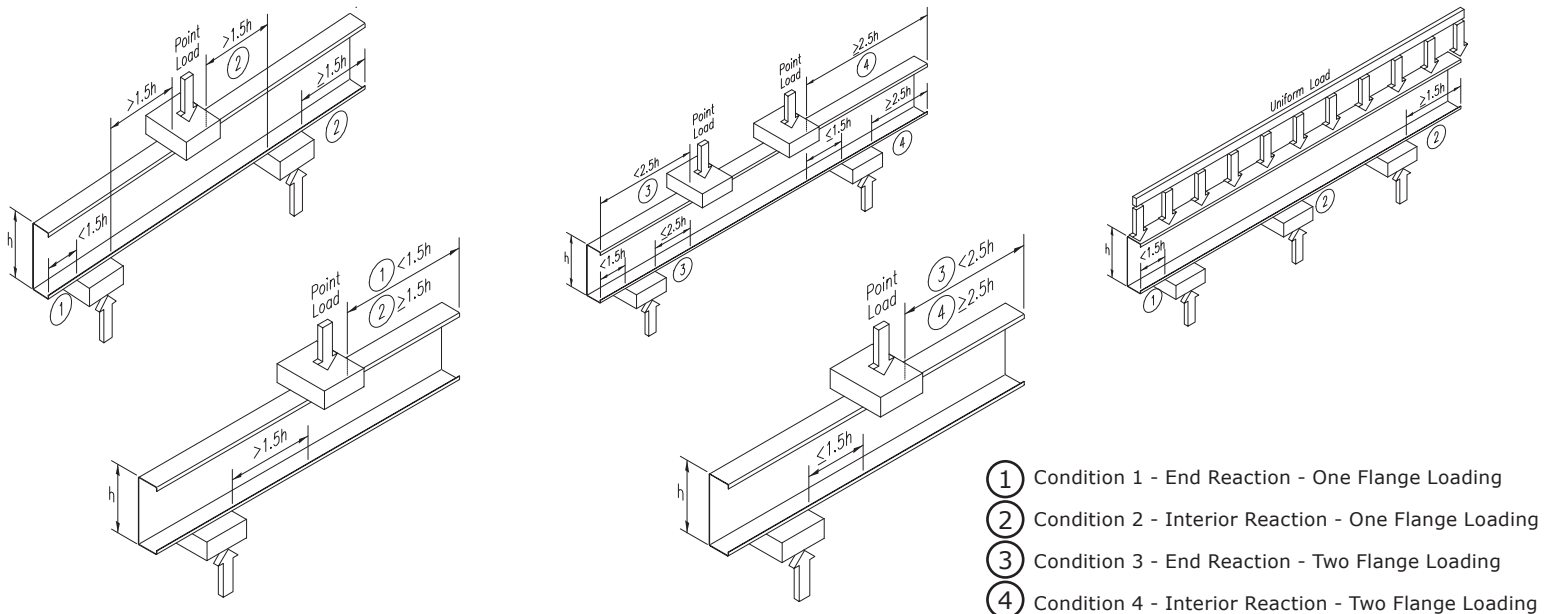

# Riverbank Acoustical

L A B O R A T O R I E S

All acoustical data was independently tested by Riverbank Acoustical Laboratories. Riverbank Acoustical is a nationally recognized company accredited by the National Institute of Standards and Technology (NIST) through the National Voluntary Laboratory Accreditation Program (NVLAP).

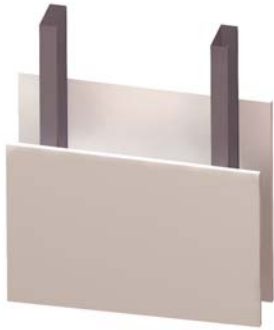

**Partition Type 1**

38 STC  
3 5/8" Stud



**Partition Type 2**

47 STC  
3 5/8" Stud



**Partition Type 3**

52 STC  
3 5/8" Stud



**Partition Type 4**

61 STC  
3 5/8" Stud

## Partition Specifications

Partition Type	Side A	Side B	Gypsum Type	Insulation Type	Stud Spacing	STC Rating
1	1 layer	1 layer	5/8" Type X	-	24" oc	38
2	1 layer	1 layer	5/8" Type X	R-11 insulated	24" oc	47
3	1 layer	1 layer on RC-1	5/8" Type X	R-11 insulated	24" oc	52
4	2 layers	2 layers on RC-1	5/8" Type X	R-11 insulated	24" oc	61

**UL Approved Designs**



**Fire Testing Data  
ASTM E 119**

*One-Hour Wall Assemblies  
Non-Load Bearing*

1 5/8" · 2 1/2" · 3 5/8" · 4" · 6"

**One-Hour  
Wall Assembly**

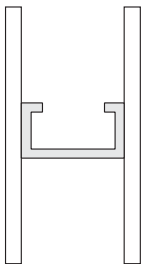

- Studs spaced 24" oc
- One layer of gypsum wallboard (GWB per UL design assembly)
- No insulation required

**One-Hour  
Chase Wall Assembly**

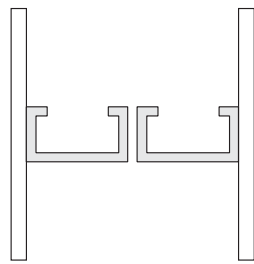

- Two rows of Supreme Studs
- Studs spaced 24" oc
- Can be aligned with 1" minimum spacing between studs from each row, staggered, or staggered and overlapped
- One layer of gypsum wallboard (GWB per UL design assembly)
- No insulation required

*Two-Hour Wall Assemblies  
Non-Load Bearing*

1 5/8" · 2 1/2" · 3 5/8" · 4" · 6"

**Two-Hour  
Wall Assembly**

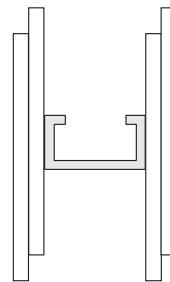

- Studs spaced 24" oc
- Two layers of gypsum wallboard (GWB per UL design assembly)
- No insulation required

**Two-Hour  
Chase Wall Assembly**

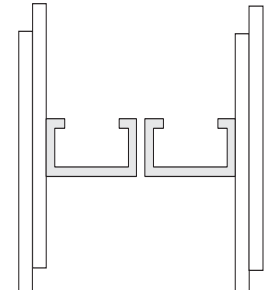

- Two rows of Supreme Studs
- Studs spaced 24" oc
- Can be aligned with 1" minimum spacing between studs from each row, staggered, or staggered and overlapped
- Two layers of gypsum wallboard (GWB per UL design assembly)
- No insulation required

**UL Classifications for  
Supreme Framing System**  
*D25 does not fall under the UL ratings at the time*

V486, V496, V498,  
U411, U412, U419,  
U435, U465, U493

Supreme Framing Deep Leg Track (SFT)							
Track Member (W)	Leg Size (H)	Gap (in)	Coating				
			D20	30EQD	33EQD	33EQS	43EQS
2 1/2", 3 1/2", 3 3/4", 4", 5 1/2", 6", 8"	2"	1/2"	G40	G40	G40	G60	G60
	2 1/2"	3/4"	G40	G40	G40	G60	G60
	3"	1"	G40	G40	G40	G60	G60

\*8" members are only available in 43EQS.

*Nomenclature Example:*

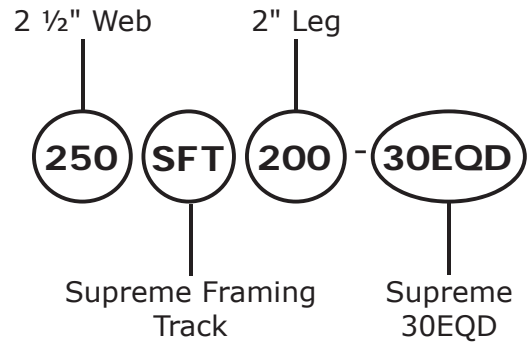

Non-sheathed with CRC 12" down from end of stud on each side



Fully sheathed with no additional bracing



Kwik-Bridged Punched Stud non-sheathed with CRC 12" down from end of stud on each side

## Supreme Z-Furring

Z-Furring channels are ideal for furring out masonry or concrete walls to support rigid insulation board, fiberglass, or mineral insulation.

- Available widths are 1", 1 1/2", and 2" (custom widths available)
- Standard lengths are 10' (additional lengths available)
- Corrosion resistant galvanized coating
- 57 ksi yield strength (mill certified steel)

Quantity / Order Information					
Part No.	Galvanized Coating	Yield Strength	Design Thickness	Web (W) Width	Stock Length (ft)
100ZF125-D20	G40	57	0.0188	1"	10
150ZF125-D20	G40	57	0.0188	1 1/2"	10
200ZF125-D20	G40	57	0.0188	2"	10
100ZF125-30EQD	G40	57	0.0235	1"	10
150ZF125-30EQD	G40	57	0.0235	1 1/2"	10
200ZF125-30EQD	G40	57	0.0235	2"	10
100ZF125-33EQD	G40	57	0.0235	1"	10
150ZF125-33EQD	G40	57	0.0235	1 1/2"	10
200ZF125-33EQD	G40	57	0.0235	2"	10
100ZF125-33EQS	G60	57	0.0295	1"	10
150ZF125-33EQS	G60	57	0.0295	1 1/2"	10
200ZF125-33EQS	G60	57	0.0295	2"	10
100ZF125-43EQS	G60	57	0.0400	1"	10
150ZF125-43EQS	G60	57	0.0400	1 1/2"	10
200ZF125-43EQS	G60	57	0.0400	2"	10

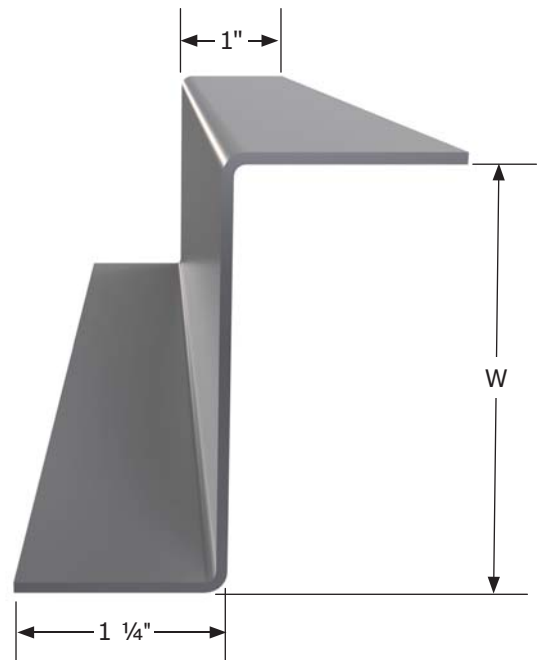



UNITED METAL PRODUCTS  
WWW.UNITEDMETALPRODUCTS.INFO

★ United Metal Products, Inc.

★ Independent Supreme Framing System Manufacturing Sites



**Nationwide Availability**



SUPREME FRAMING SYSTEM®

[www.SSFS.com](http://www.SSFS.com)

## United Metal Products

234 N. Sherman Avenue  
Corona, CA 92882-1843

Ph: 951-739-9535

Fx: 951-739-9536

[www.UnitedMetalProducts.info](http://www.UnitedMetalProducts.info)